21 Data Structures for Disjoint Sets

Some applications involve grouping n distinct elements into a collection of disjoint sets. These applications often need to perform two operations in particular: finding the unique set that contains a given element and uniting two sets. This chapter explores methods for maintaining a data structure that supports these operations.

Section 21.1 describes the operations supported by a disjoint-set data structure and presents a simple application. In Section 21.2, we look at a simple linked-list implementation for disjoint sets. Section 21.3 presents a more efficient representation using rooted trees. The running time using the tree representation is theoretically superlinear, but for all practical purposes it is linear. Section 21.4 defines and discusses a very quickly growing function and its very slowly growing inverse, which appears in the running time of operations on the tree-based implementation, and then, by a complex amortized analysis, proves an upper bound on the running time that is just barely superlinear.

21.1 Disjoint-set operations

A *disjoint-set data structure* maintains a collection $\mathcal{S} = \{S_1, S_2, \dots, S_k\}$ of disjoint dynamic sets. We identify each set by a *representative*, which is some member of the set. In some applications, it doesn't matter which member is used as the representative; we care only that if we ask for the representative of a dynamic set twice without modifying the set between the requests, we get the same answer both times. Other applications may require a prespecified rule for choosing the representative, such as choosing the smallest member in the set (assuming, of course, that the elements can be ordered).

As in the other dynamic-set implementations we have studied, we represent each element of a set by an object. Letting x denote an object, we wish to support the following operations:

MAKE-SET(x) creates a new set whose only member (and thus representative) is x . Since the sets are disjoint, we require that x not already be in some other set.

UNION(x, y) unites the dynamic sets that contain x and y , say S_x and S_y , into a new set that is the union of these two sets. We assume that the two sets are disjoint prior to the operation. The representative of the resulting set is any member of $S_x \cup S_y$, although many implementations of **UNION** specifically choose the representative of either S_x or S_y as the new representative. Since we require the sets in the collection to be disjoint, conceptually we destroy sets S_x and S_y , removing them from the collection \mathcal{S} . In practice, we often absorb the elements of one of the sets into the other set.

FIND-SET(x) returns a pointer to the representative of the (unique) set containing x .

Throughout this chapter, we shall analyze the running times of disjoint-set data structures in terms of two parameters: n , the number of **MAKE-SET** operations, and m , the total number of **MAKE-SET**, **UNION**, and **FIND-SET** operations. Since the sets are disjoint, each **UNION** operation reduces the number of sets by one. After $n - 1$ **UNION** operations, therefore, only one set remains. The number of **UNION** operations is thus at most $n - 1$. Note also that since the **MAKE-SET** operations are included in the total number of operations m , we have $m \geq n$. We assume that the n **MAKE-SET** operations are the first n operations performed.

An application of disjoint-set data structures

One of the many applications of disjoint-set data structures arises in determining the connected components of an undirected graph (see Section B.4). Figure 21.1(a), for example, shows a graph with four connected components.

The procedure **CONNECTED-COMPONENTS** that follows uses the disjoint-set operations to compute the connected components of a graph. Once **CONNECTED-COMPONENTS** has preprocessed the graph, the procedure **SAME-COMPONENT** answers queries about whether two vertices are in the same connected component.¹ (In pseudocode, we denote the set of vertices of a graph G by $G.V$ and the set of edges by $G.E$.)

¹When the edges of the graph are static—not changing over time—we can compute the connected components faster by using depth-first search (Exercise 22.3-12). Sometimes, however, the edges are added dynamically and we need to maintain the connected components as each edge is added. In this case, the implementation given here can be more efficient than running a new depth-first search for each new edge.

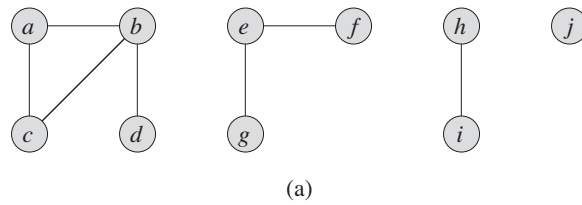

Edge processed	Collection of disjoint sets									
initial sets	{a}	{b}	{c}	{d}	{e}	{f}	{g}	{h}	{i}	{j}
(b,d)	{a}	{b,d}	{c}		{e}	{f}	{g}	{h}	{i}	{j}
(e,g)	{a}	{b,d}	{c}		{e,g}	{f}		{h}	{i}	{j}
(a,c)	{a,c}	{b,d}			{e,g}	{f}		{h}	{i}	{j}
(h,i)	{a,c}	{b,d}			{e,g}	{f}		{h,i}		{j}
(a,b)	{a,b,c,d}				{e,g}	{f}		{h,i}		{j}
(e,f)	{a,b,c,d}				{e,f,g}			{h,i}		{j}
(b,c)	{a,b,c,d}				{e,f,g}			{h,i}		{j}

(b)

Figure 21.1 (a) A graph with four connected components: $\{a, b, c, d\}$, $\{e, f, g\}$, $\{h, i\}$, and $\{j\}$.
 (b) The collection of disjoint sets after processing each edge.

CONNECTED-COMPONENTS(G)

```

1  for each vertex  $v \in G.V$ 
2      MAKE-SET( $v$ )
3  for each edge  $(u, v) \in G.E$ 
4      if FIND-SET( $u$ )  $\neq$  FIND-SET( $v$ )
5          UNION( $u, v$ )
  
```

SAME-COMPONENT(u, v)

```

1  if FIND-SET( $u$ ) == FIND-SET( $v$ )
2      return TRUE
3  else return FALSE
  
```

The procedure `CONNECTED-COMPONENTS` initially places each vertex v in its own set. Then, for each edge (u, v) , it unites the sets containing u and v . By Exercise 21.1-2, after processing all the edges, two vertices are in the same connected component if and only if the corresponding objects are in the same set. Thus, `CONNECTED-COMPONENTS` computes sets in such a way that the procedure `SAME-COMPONENT` can determine whether two vertices are in the same con-

nected component. Figure 21.1(b) illustrates how CONNECTED-COMPONENTS computes the disjoint sets.

In an actual implementation of this connected-components algorithm, the representations of the graph and the disjoint-set data structure would need to reference each other. That is, an object representing a vertex would contain a pointer to the corresponding disjoint-set object, and vice versa. These programming details depend on the implementation language, and we do not address them further here.

Exercises

21.1-1

Suppose that CONNECTED-COMPONENTS is run on the undirected graph $G = (V, E)$, where $V = \{a, b, c, d, e, f, g, h, i, j, k\}$ and the edges of E are processed in the order $(d, i), (f, k), (g, i), (b, g), (a, h), (i, j), (d, k), (b, j), (d, f), (g, j), (a, e)$. List the vertices in each connected component after each iteration of lines 3–5.

21.1-2

Show that after all edges are processed by CONNECTED-COMPONENTS, two vertices are in the same connected component if and only if they are in the same set.

21.1-3

During the execution of CONNECTED-COMPONENTS on an undirected graph $G = (V, E)$ with k connected components, how many times is FIND-SET called? How many times is UNION called? Express your answers in terms of $|V|$, $|E|$, and k .

21.2 Linked-list representation of disjoint sets

Figure 21.2(a) shows a simple way to implement a disjoint-set data structure: each set is represented by its own linked list. The object for each set has attributes *head*, pointing to the first object in the list, and *tail*, pointing to the last object. Each object in the list contains a set member, a pointer to the next object in the list, and a pointer back to the set object. Within each linked list, the objects may appear in any order. The representative is the set member in the first object in the list.

With this linked-list representation, both MAKE-SET and FIND-SET are easy, requiring $O(1)$ time. To carry out MAKE-SET(x), we create a new linked list whose only object is x . For FIND-SET(x), we just follow the pointer from x back to its set object and then return the member in the object that *head* points to. For example, in Figure 21.2(a), the call FIND-SET(g) would return f .

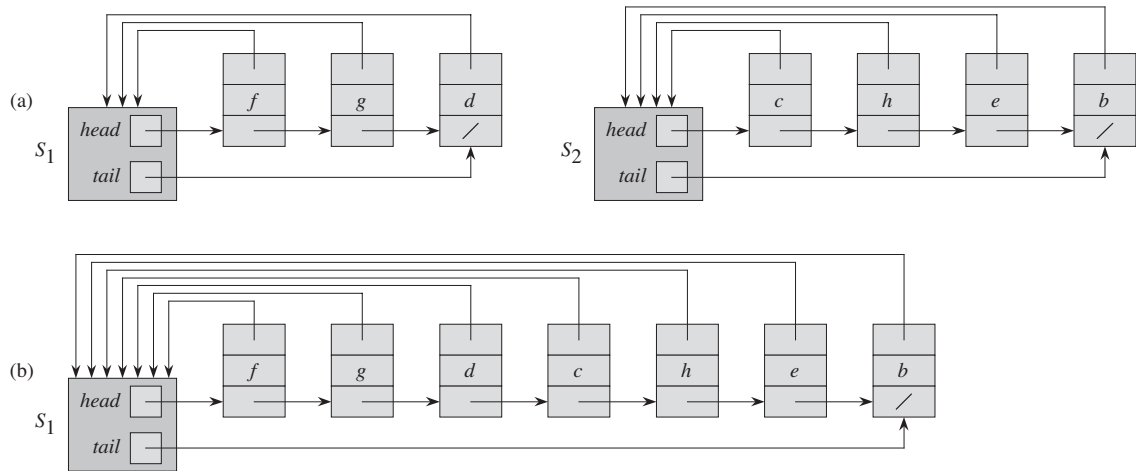

Figure 21.2 (a) Linked-list representations of two sets. Set S_1 contains members d , f , and g , with representative f , and set S_2 contains members b , c , e , and h , with representative c . Each object in the list contains a set member, a pointer to the next object in the list, and a pointer back to the set object. Each set object has pointers *head* and *tail* to the first and last objects, respectively. (b) The result of $\text{UNION}(g, e)$, which appends the linked list containing e to the linked list containing g . The representative of the resulting set is f . The set object for e 's list, S_2 , is destroyed.

A simple implementation of union

The simplest implementation of the UNION operation using the linked-list set representation takes significantly more time than MAKE-SET or FIND-SET. As Figure 21.2(b) shows, we perform $\text{UNION}(x, y)$ by appending y 's list onto the end of x 's list. The representative of x 's list becomes the representative of the resulting set. We use the *tail* pointer for x 's list to quickly find where to append y 's list. Because all members of y 's list join x 's list, we can destroy the set object for y 's list. Unfortunately, we must update the pointer to the set object for each object originally on y 's list, which takes time linear in the length of y 's list. In Figure 21.2, for example, the operation $\text{UNION}(g, e)$ causes pointers to be updated in the objects for b , c , e , and h .

In fact, we can easily construct a sequence of m operations on n objects that requires $\Theta(n^2)$ time. Suppose that we have objects x_1, x_2, \dots, x_n . We execute the sequence of n MAKE-SET operations followed by $n - 1$ UNION operations shown in Figure 21.3, so that $m = 2n - 1$. We spend $\Theta(n)$ time performing the n MAKE-SET operations. Because the i th UNION operation updates i objects, the total number of objects updated by all $n - 1$ UNION operations is

Operation	Number of objects updated
MAKE-SET(x_1)	1
MAKE-SET(x_2)	1
\vdots	\vdots
MAKE-SET(x_n)	1
UNION(x_2, x_1)	1
UNION(x_3, x_2)	2
UNION(x_4, x_3)	3
\vdots	\vdots
UNION(x_n, x_{n-1})	$n - 1$

Figure 21.3 A sequence of $2n - 1$ operations on n objects that takes $\Theta(n^2)$ time, or $\Theta(n)$ time per operation on average, using the linked-list set representation and the simple implementation of UNION.

$$\sum_{i=1}^{n-1} i = \Theta(n^2).$$

The total number of operations is $2n - 1$, and so each operation on average requires $\Theta(n)$ time. That is, the amortized time of an operation is $\Theta(n)$.

A weighted-union heuristic

In the worst case, the above implementation of the UNION procedure requires an average of $\Theta(n)$ time per call because we may be appending a longer list onto a shorter list; we must update the pointer to the set object for each member of the longer list. Suppose instead that each list also includes the length of the list (which we can easily maintain) and that we always append the shorter list onto the longer, breaking ties arbitrarily. With this simple *weighted-union heuristic*, a single UNION operation can still take $\Omega(n)$ time if both sets have $\Omega(n)$ members. As the following theorem shows, however, a sequence of m MAKE-SET, UNION, and FIND-SET operations, n of which are MAKE-SET operations, takes $O(m + n \lg n)$ time.

Theorem 21.1

Using the linked-list representation of disjoint sets and the weighted-union heuristic, a sequence of m MAKE-SET, UNION, and FIND-SET operations, n of which are MAKE-SET operations, takes $O(m + n \lg n)$ time.

Proof Because each UNION operation unites two disjoint sets, we perform at most $n - 1$ UNION operations over all. We now bound the total time taken by these UNION operations. We start by determining, for each object, an upper bound on the number of times the object's pointer back to its set object is updated. Consider a particular object x . We know that each time x 's pointer was updated, x must have started in the smaller set. The first time x 's pointer was updated, therefore, the resulting set must have had at least 2 members. Similarly, the next time x 's pointer was updated, the resulting set must have had at least 4 members. Continuing on, we observe that for any $k \leq n$, after x 's pointer has been updated $\lceil \lg k \rceil$ times, the resulting set must have at least k members. Since the largest set has at most n members, each object's pointer is updated at most $\lceil \lg n \rceil$ times over all the UNION operations. Thus the total time spent updating object pointers over all UNION operations is $O(n \lg n)$. We must also account for updating the *tail* pointers and the list lengths, which take only $\Theta(1)$ time per UNION operation. The total time spent in all UNION operations is thus $O(n \lg n)$.

The time for the entire sequence of m operations follows easily. Each MAKE-SET and FIND-SET operation takes $O(1)$ time, and there are $O(m)$ of them. The total time for the entire sequence is thus $O(m + n \lg n)$. ■

Exercises

21.2-1

Write pseudocode for MAKE-SET, FIND-SET, and UNION using the linked-list representation and the weighted-union heuristic. Make sure to specify the attributes that you assume for set objects and list objects.

21.2-2

Show the data structure that results and the answers returned by the FIND-SET operations in the following program. Use the linked-list representation with the weighted-union heuristic.

```

1  for  $i = 1$  to 16
2      MAKE-SET( $x_i$ )
3  for  $i = 1$  to 15 by 2
4      UNION( $x_i, x_{i+1}$ )
5  for  $i = 1$  to 13 by 4
6      UNION( $x_i, x_{i+2}$ )
7  UNION( $x_1, x_5$ )
8  UNION( $x_{11}, x_{13}$ )
9  UNION( $x_1, x_{10}$ )
10 FIND-SET( $x_2$ )
11 FIND-SET( $x_9$ )

```

Assume that if the sets containing x_i and x_j have the same size, then the operation $\text{UNION}(x_i, x_j)$ appends x_j 's list onto x_i 's list.

21.2-3

Adapt the aggregate proof of Theorem 21.1 to obtain amortized time bounds of $O(1)$ for MAKE-SET and FIND-SET and $O(\lg n)$ for UNION using the linked-list representation and the weighted-union heuristic.

21.2-4

Give a tight asymptotic bound on the running time of the sequence of operations in Figure 21.3 assuming the linked-list representation and the weighted-union heuristic.

21.2-5

Professor Gompers suspects that it might be possible to keep just one pointer in each set object, rather than two (*head* and *tail*), while keeping the number of pointers in each list element at two. Show that the professor's suspicion is well founded by describing how to represent each set by a linked list such that each operation has the same running time as the operations described in this section. Describe also how the operations work. Your scheme should allow for the weighted-union heuristic, with the same effect as described in this section. (*Hint*: Use the tail of a linked list as its set's representative.)

21.2-6

Suggest a simple change to the UNION procedure for the linked-list representation that removes the need to keep the *tail* pointer to the last object in each list. Whether or not the weighted-union heuristic is used, your change should not change the asymptotic running time of the UNION procedure. (*Hint*: Rather than appending one list to another, splice them together.)

21.3 Disjoint-set forests

In a faster implementation of disjoint sets, we represent sets by rooted trees, with each node containing one member and each tree representing one set. In a *disjoint-set forest*, illustrated in Figure 21.4(a), each member points only to its parent. The root of each tree contains the representative and is its own parent. As we shall see, although the straightforward algorithms that use this representation are no faster than ones that use the linked-list representation, by introducing two heuristics—"union by rank" and "path compression"—we can achieve an asymptotically optimal disjoint-set data structure.

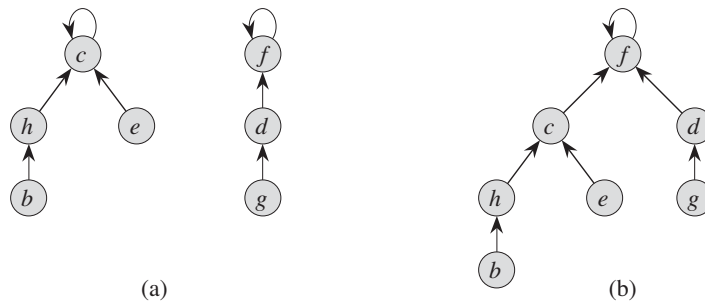

Figure 21.4 A disjoint-set forest. **(a)** Two trees representing the two sets of Figure 21.2. The tree on the left represents the set $\{b, c, e, h\}$, with c as the representative, and the tree on the right represents the set $\{d, f, g\}$, with f as the representative. **(b)** The result of $\text{UNION}(e, g)$.

We perform the three disjoint-set operations as follows. A **MAKE-SET** operation simply creates a tree with just one node. We perform a **FIND-SET** operation by following parent pointers until we find the root of the tree. The nodes visited on this simple path toward the root constitute the *find path*. A **UNION** operation, shown in Figure 21.4(b), causes the root of one tree to point to the root of the other.

Heuristics to improve the running time

So far, we have not improved on the linked-list implementation. A sequence of $n - 1$ **UNION** operations may create a tree that is just a linear chain of n nodes. By using two heuristics, however, we can achieve a running time that is almost linear in the total number of operations m .

The first heuristic, *union by rank*, is similar to the weighted-union heuristic we used with the linked-list representation. The obvious approach would be to make the root of the tree with fewer nodes point to the root of the tree with more nodes. Rather than explicitly keeping track of the size of the subtree rooted at each node, we shall use an approach that eases the analysis. For each node, we maintain a *rank*, which is an upper bound on the height of the node. In union by rank, we make the root with smaller rank point to the root with larger rank during a **UNION** operation.

The second heuristic, *path compression*, is also quite simple and highly effective. As shown in Figure 21.5, we use it during **FIND-SET** operations to make each node on the find path point directly to the root. Path compression does not change any ranks.

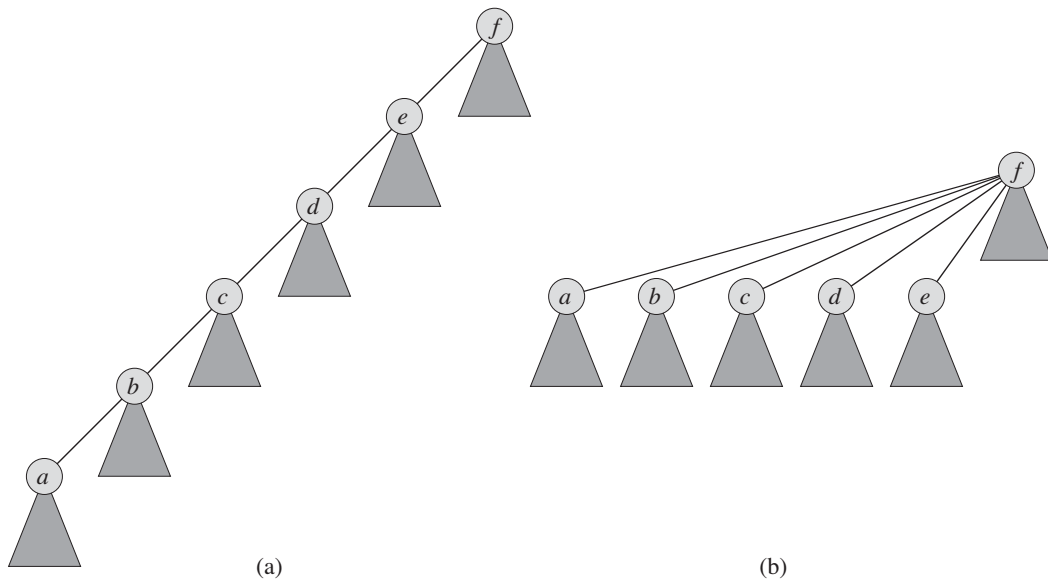

Figure 21.5 Path compression during the operation FIND-SET . Arrows and self-loops at roots are omitted. **(a)** A tree representing a set prior to executing $\text{FIND-SET}(a)$. Triangles represent subtrees whose roots are the nodes shown. Each node has a pointer to its parent. **(b)** The same set after executing $\text{FIND-SET}(a)$. Each node on the find path now points directly to the root.

Pseudocode for disjoint-set forests

To implement a disjoint-set forest with the union-by-rank heuristic, we must keep track of ranks. With each node x , we maintain the integer value $x.\text{rank}$, which is an upper bound on the height of x (the number of edges in the longest simple path between x and a descendant leaf). When MAKE-SET creates a singleton set, the single node in the corresponding tree has an initial rank of 0. Each FIND-SET operation leaves all ranks unchanged. The UNION operation has two cases, depending on whether the roots of the trees have equal rank. If the roots have unequal rank, we make the root with higher rank the parent of the root with lower rank, but the ranks themselves remain unchanged. If, instead, the roots have equal ranks, we arbitrarily choose one of the roots as the parent and increment its rank.

Let us put this method into pseudocode. We designate the parent of node x by $x.p$. The LINK procedure, a subroutine called by UNION , takes pointers to two roots as inputs.

MAKE-SET(x)

```
1  $x.p = x$ 
2  $x.rank = 0$ 
```

UNION(x, y)

```
1 LINK(FIND-SET( $x$ ), FIND-SET( $y$ ))
```

LINK(x, y)

```
1 if  $x.rank > y.rank$ 
2      $y.p = x$ 
3 else  $x.p = y$ 
4     if  $x.rank == y.rank$ 
5          $y.rank = y.rank + 1$ 
```

The FIND-SET procedure with path compression is quite simple:

FIND-SET(x)

```
1 if  $x \neq x.p$ 
2      $x.p = \text{FIND-SET}(x.p)$ 
3 return  $x.p$ 
```

The FIND-SET procedure is a *two-pass method*: as it recurses, it makes one pass up the find path to find the root, and as the recursion unwinds, it makes a second pass back down the find path to update each node to point directly to the root. Each call of FIND-SET(x) returns $x.p$ in line 3. If x is the root, then FIND-SET skips line 2 and instead returns $x.p$, which is x ; this is the case in which the recursion bottoms out. Otherwise, line 2 executes, and the recursive call with parameter $x.p$ returns a pointer to the root. Line 2 updates node x to point directly to the root, and line 3 returns this pointer.

Effect of the heuristics on the running time

Separately, either union by rank or path compression improves the running time of the operations on disjoint-set forests, and the improvement is even greater when we use the two heuristics together. Alone, union by rank yields a running time of $O(m \lg n)$ (see Exercise 21.4-4), and this bound is tight (see Exercise 21.3-3). Although we shall not prove it here, for a sequence of n MAKE-SET operations (and hence at most $n - 1$ UNION operations) and f FIND-SET operations, the path-compression heuristic alone gives a worst-case running time of $\Theta(n + f \cdot (1 + \log_{2+f/n} n))$.

When we use both union by rank and path compression, the worst-case running time is $O(m \alpha(n))$, where $\alpha(n)$ is a *very* slowly growing function, which we define in Section 21.4. In any conceivable application of a disjoint-set data structure, $\alpha(n) \leq 4$; thus, we can view the running time as linear in m in all practical situations. Strictly speaking, however, it is superlinear. In Section 21.4, we prove this upper bound.

Exercises

21.3-1

Redo Exercise 21.2-2 using a disjoint-set forest with union by rank and path compression.

21.3-2

Write a nonrecursive version of FIND-SET with path compression.

21.3-3

Give a sequence of m MAKE-SET, UNION, and FIND-SET operations, n of which are MAKE-SET operations, that takes $\Omega(m \lg n)$ time when we use union by rank only.

21.3-4

Suppose that we wish to add the operation PRINT-SET(x), which is given a node x and prints all the members of x 's set, in any order. Show how we can add just a single attribute to each node in a disjoint-set forest so that PRINT-SET(x) takes time linear in the number of members of x 's set and the asymptotic running times of the other operations are unchanged. Assume that we can print each member of the set in $O(1)$ time.

21.3-5 ★

Show that any sequence of m MAKE-SET, FIND-SET, and LINK operations, where all the LINK operations appear before any of the FIND-SET operations, takes only $O(m)$ time if we use both path compression and union by rank. What happens in the same situation if we use only the path-compression heuristic?

★ 21.4 Analysis of union by rank with path compression

As noted in Section 21.3, the combined union-by-rank and path-compression heuristic runs in time $O(m \alpha(n))$ for m disjoint-set operations on n elements. In this section, we shall examine the function α to see just how slowly it grows. Then we prove this running time using the potential method of amortized analysis.

A very quickly growing function and its very slowly growing inverse

For integers $k \geq 0$ and $j \geq 1$, we define the function $A_k(j)$ as

$$A_k(j) = \begin{cases} j + 1 & \text{if } k = 0, \\ A_{k-1}^{(j+1)}(j) & \text{if } k \geq 1, \end{cases}$$

where the expression $A_{k-1}^{(j+1)}(j)$ uses the functional-iteration notation given in Section 3.2. Specifically, $A_{k-1}^{(0)}(j) = j$ and $A_{k-1}^{(i)}(j) = A_{k-1}(A_{k-1}^{(i-1)}(j))$ for $i \geq 1$. We will refer to the parameter k as the *level* of the function A .

The function $A_k(j)$ strictly increases with both j and k . To see just how quickly this function grows, we first obtain closed-form expressions for $A_1(j)$ and $A_2(j)$.

Lemma 21.2

For any integer $j \geq 1$, we have $A_1(j) = 2j + 1$.

Proof We first use induction on i to show that $A_0^{(i)}(j) = j + i$. For the base case, we have $A_0^{(0)}(j) = j = j + 0$. For the inductive step, assume that $A_0^{(i-1)}(j) = j + (i - 1)$. Then $A_0^{(i)}(j) = A_0(A_0^{(i-1)}(j)) = (j + (i - 1)) + 1 = j + i$. Finally, we note that $A_1(j) = A_0^{(j+1)}(j) = j + (j + 1) = 2j + 1$. ■

Lemma 21.3

For any integer $j \geq 1$, we have $A_2(j) = 2^{j+1}(j + 1) - 1$.

Proof We first use induction on i to show that $A_1^{(i)}(j) = 2^i(j + 1) - 1$. For the base case, we have $A_1^{(0)}(j) = j = 2^0(j + 1) - 1$. For the inductive step, assume that $A_1^{(i-1)}(j) = 2^{i-1}(j + 1) - 1$. Then $A_1^{(i)}(j) = A_1(A_1^{(i-1)}(j)) = A_1(2^{i-1}(j + 1) - 1) = 2 \cdot (2^{i-1}(j + 1) - 1) + 1 = 2^i(j + 1) - 2 + 1 = 2^i(j + 1) - 1$. Finally, we note that $A_2(j) = A_1^{(j+1)}(j) = 2^{j+1}(j + 1) - 1$. ■

Now we can see how quickly $A_k(j)$ grows by simply examining $A_k(1)$ for levels $k = 0, 1, 2, 3, 4$. From the definition of $A_0(k)$ and the above lemmas, we have $A_0(1) = 1 + 1 = 2$, $A_1(1) = 2 \cdot 1 + 1 = 3$, and $A_2(1) = 2^{1+1} \cdot (1 + 1) - 1 = 7$.

We also have

$$\begin{aligned}
 A_3(1) &= A_2^{(2)}(1) \\
 &= A_2(A_2(1)) \\
 &= A_2(7) \\
 &= 2^8 \cdot 8 - 1 \\
 &= 2^{11} - 1 \\
 &= 2047
 \end{aligned}$$

and

$$\begin{aligned}
 A_4(1) &= A_3^{(2)}(1) \\
 &= A_3(A_3(1)) \\
 &= A_3(2047) \\
 &= A_2^{(2048)}(2047) \\
 &\gg A_2(2047) \\
 &= 2^{2048} \cdot 2048 - 1 \\
 &> 2^{2048} \\
 &= (2^4)^{512} \\
 &= 16^{512} \\
 &\gg 10^{80},
 \end{aligned}$$

which is the estimated number of atoms in the observable universe. (The symbol “ \gg ” denotes the “much-greater-than” relation.)

We define the inverse of the function $A_k(n)$, for integer $n \geq 0$, by

$$\alpha(n) = \min \{k : A_k(1) \geq n\} .$$

In words, $\alpha(n)$ is the lowest level k for which $A_k(1)$ is at least n . From the above values of $A_k(1)$, we see that

$$\alpha(n) = \begin{cases} 0 & \text{for } 0 \leq n \leq 2, \\ 1 & \text{for } n = 3, \\ 2 & \text{for } 4 \leq n \leq 7, \\ 3 & \text{for } 8 \leq n \leq 2047, \\ 4 & \text{for } 2048 \leq n \leq A_4(1). \end{cases}$$

It is only for values of n so large that the term “astronomical” understates them (greater than $A_4(1)$, a huge number) that $\alpha(n) > 4$, and so $\alpha(n) \leq 4$ for all practical purposes.

Properties of ranks

In the remainder of this section, we prove an $O(m\alpha(n))$ bound on the running time of the disjoint-set operations with union by rank and path compression. In order to prove this bound, we first prove some simple properties of ranks.

Lemma 21.4

For all nodes x , we have $x.rank \leq x.p.rank$, with strict inequality if $x \neq x.p$. The value of $x.rank$ is initially 0 and increases through time until $x \neq x.p$; from then on, $x.rank$ does not change. The value of $x.p.rank$ monotonically increases over time.

Proof The proof is a straightforward induction on the number of operations, using the implementations of MAKE-SET, UNION, and FIND-SET that appear in Section 21.3. We leave it as Exercise 21.4-1. ■

Corollary 21.5

As we follow the simple path from any node toward a root, the node ranks strictly increase. ■

Lemma 21.6

Every node has rank at most $n - 1$.

Proof Each node's rank starts at 0, and it increases only upon LINK operations. Because there are at most $n - 1$ UNION operations, there are also at most $n - 1$ LINK operations. Because each LINK operation either leaves all ranks alone or increases some node's rank by 1, all ranks are at most $n - 1$. ■

Lemma 21.6 provides a weak bound on ranks. In fact, every node has rank at most $\lceil \lg n \rceil$ (see Exercise 21.4-2). The looser bound of Lemma 21.6 will suffice for our purposes, however.

Proving the time bound

We shall use the potential method of amortized analysis (see Section 17.3) to prove the $O(m\alpha(n))$ time bound. In performing the amortized analysis, we will find it convenient to assume that we invoke the LINK operation rather than the UNION operation. That is, since the parameters of the LINK procedure are pointers to two roots, we act as though we perform the appropriate FIND-SET operations separately. The following lemma shows that even if we count the extra FIND-SET operations induced by UNION calls, the asymptotic running time remains unchanged.

Lemma 21.7

Suppose we convert a sequence S' of m' MAKE-SET, UNION, and FIND-SET operations into a sequence S of m MAKE-SET, LINK, and FIND-SET operations by turning each UNION into two FIND-SET operations followed by a LINK. Then, if sequence S runs in $O(m \alpha(n))$ time, sequence S' runs in $O(m' \alpha(n))$ time.

Proof Since each UNION operation in sequence S' is converted into three operations in S , we have $m' \leq m \leq 3m'$. Since $m = O(m')$, an $O(m \alpha(n))$ time bound for the converted sequence S implies an $O(m' \alpha(n))$ time bound for the original sequence S' . ■

In the remainder of this section, we shall assume that the initial sequence of m' MAKE-SET, UNION, and FIND-SET operations has been converted to a sequence of m MAKE-SET, LINK, and FIND-SET operations. We now prove an $O(m \alpha(n))$ time bound for the converted sequence and appeal to Lemma 21.7 to prove the $O(m' \alpha(n))$ running time of the original sequence of m' operations.

Potential function

The potential function we use assigns a potential $\phi_q(x)$ to each node x in the disjoint-set forest after q operations. We sum the node potentials for the potential of the entire forest: $\Phi_q = \sum_x \phi_q(x)$, where Φ_q denotes the potential of the forest after q operations. The forest is empty prior to the first operation, and we arbitrarily set $\Phi_0 = 0$. No potential Φ_q will ever be negative.

The value of $\phi_q(x)$ depends on whether x is a tree root after the q th operation. If it is, or if $x.rank = 0$, then $\phi_q(x) = \alpha(n) \cdot x.rank$.

Now suppose that after the q th operation, x is not a root and that $x.rank \geq 1$. We need to define two auxiliary functions on x before we can define $\phi_q(x)$. First we define

$$\text{level}(x) = \max \{k : x.p.rank \geq A_k(x.rank)\} .$$

That is, $\text{level}(x)$ is the greatest level k for which A_k , applied to x 's rank, is no greater than x 's parent's rank.

We claim that

$$0 \leq \text{level}(x) < \alpha(n) , \tag{21.1}$$

which we see as follows. We have

$$\begin{aligned} x.p.rank &\geq x.rank + 1 \quad (\text{by Lemma 21.4}) \\ &= A_0(x.rank) \quad (\text{by definition of } A_0(j)) , \end{aligned}$$

which implies that $\text{level}(x) \geq 0$, and we have

$$\begin{aligned}
A_{\alpha(n)}(x.rank) &\geq A_{\alpha(n)}(1) && \text{(because } A_k(j) \text{ is strictly increasing)} \\
&\geq n && \text{(by the definition of } \alpha(n)) \\
&> x.p.rank && \text{(by Lemma 21.6) ,}
\end{aligned}$$

which implies that $\text{level}(x) < \alpha(n)$. Note that because $x.p.rank$ monotonically increases over time, so does $\text{level}(x)$.

The second auxiliary function applies when $x.rank \geq 1$:

$$\text{iter}(x) = \max \{i : x.p.rank \geq A_{\text{level}(x)}^{(i)}(x.rank)\} .$$

That is, $\text{iter}(x)$ is the largest number of times we can iteratively apply $A_{\text{level}(x)}$, applied initially to x 's rank, before we get a value greater than x 's parent's rank.

We claim that when $x.rank \geq 1$, we have

$$1 \leq \text{iter}(x) \leq x.rank , \tag{21.2}$$

which we see as follows. We have

$$\begin{aligned}
x.p.rank &\geq A_{\text{level}(x)}(x.rank) && \text{(by definition of } \text{level}(x)) \\
&= A_{\text{level}(x)}^{(1)}(x.rank) && \text{(by definition of functional iteration) ,}
\end{aligned}$$

which implies that $\text{iter}(x) \geq 1$, and we have

$$\begin{aligned}
A_{\text{level}(x)}^{(x.rank+1)}(x.rank) &= A_{\text{level}(x)+1}(x.rank) && \text{(by definition of } A_k(j)) \\
&> x.p.rank && \text{(by definition of } \text{level}(x)) ,
\end{aligned}$$

which implies that $\text{iter}(x) \leq x.rank$. Note that because $x.p.rank$ monotonically increases over time, in order for $\text{iter}(x)$ to decrease, $\text{level}(x)$ must increase. As long as $\text{level}(x)$ remains unchanged, $\text{iter}(x)$ must either increase or remain unchanged.

With these auxiliary functions in place, we are ready to define the potential of node x after q operations:

$$\phi_q(x) = \begin{cases} \alpha(n) \cdot x.rank & \text{if } x \text{ is a root or } x.rank = 0 , \\ (\alpha(n) - \text{level}(x)) \cdot x.rank - \text{iter}(x) & \text{if } x \text{ is not a root and } x.rank \geq 1 . \end{cases}$$

We next investigate some useful properties of node potentials.

Lemma 21.8

For every node x , and for all operation counts q , we have

$$0 \leq \phi_q(x) \leq \alpha(n) \cdot x.rank .$$

Proof If x is a root or $x.rank = 0$, then $\phi_q(x) = \alpha(n) \cdot x.rank$ by definition. Now suppose that x is not a root and that $x.rank \geq 1$. We obtain a lower bound on $\phi_q(x)$ by maximizing $level(x)$ and $iter(x)$. By the bound (21.1), $level(x) \leq \alpha(n) - 1$, and by the bound (21.2), $iter(x) \leq x.rank$. Thus,

$$\begin{aligned} \phi_q(x) &= (\alpha(n) - level(x)) \cdot x.rank - iter(x) \\ &\geq (\alpha(n) - (\alpha(n) - 1)) \cdot x.rank - x.rank \\ &= x.rank - x.rank \\ &= 0. \end{aligned}$$

Similarly, we obtain an upper bound on $\phi_q(x)$ by minimizing $level(x)$ and $iter(x)$. By the bound (21.1), $level(x) \geq 0$, and by the bound (21.2), $iter(x) \geq 1$. Thus,

$$\begin{aligned} \phi_q(x) &\leq (\alpha(n) - 0) \cdot x.rank - 1 \\ &= \alpha(n) \cdot x.rank - 1 \\ &< \alpha(n) \cdot x.rank. \end{aligned} \quad \blacksquare$$

Corollary 21.9

If node x is not a root and $x.rank > 0$, then $\phi_q(x) < \alpha(n) \cdot x.rank$. ■

Potential changes and amortized costs of operations

We are now ready to examine how the disjoint-set operations affect node potentials. With an understanding of the change in potential due to each operation, we can determine each operation's amortized cost.

Lemma 21.10

Let x be a node that is not a root, and suppose that the q th operation is either a LINK or FIND-SET. Then after the q th operation, $\phi_q(x) \leq \phi_{q-1}(x)$. Moreover, if $x.rank \geq 1$ and either $level(x)$ or $iter(x)$ changes due to the q th operation, then $\phi_q(x) \leq \phi_{q-1}(x) - 1$. That is, x 's potential cannot increase, and if it has positive rank and either $level(x)$ or $iter(x)$ changes, then x 's potential drops by at least 1.

Proof Because x is not a root, the q th operation does not change $x.rank$, and because n does not change after the initial n MAKE-SET operations, $\alpha(n)$ remains unchanged as well. Hence, these components of the formula for x 's potential remain the same after the q th operation. If $x.rank = 0$, then $\phi_q(x) = \phi_{q-1}(x) = 0$. Now assume that $x.rank \geq 1$.

Recall that $level(x)$ monotonically increases over time. If the q th operation leaves $level(x)$ unchanged, then $iter(x)$ either increases or remains unchanged. If both $level(x)$ and $iter(x)$ are unchanged, then $\phi_q(x) = \phi_{q-1}(x)$. If $level(x)$

is unchanged and $\text{iter}(x)$ increases, then it increases by at least 1, and so $\phi_q(x) \leq \phi_{q-1}(x) - 1$.

Finally, if the q th operation increases $\text{level}(x)$, it increases by at least 1, so that the value of the term $(\alpha(n) - \text{level}(x)) \cdot x.\text{rank}$ drops by at least $x.\text{rank}$. Because $\text{level}(x)$ increased, the value of $\text{iter}(x)$ might drop, but according to the bound (21.2), the drop is by at most $x.\text{rank} - 1$. Thus, the increase in potential due to the change in $\text{iter}(x)$ is less than the decrease in potential due to the change in $\text{level}(x)$, and we conclude that $\phi_q(x) \leq \phi_{q-1}(x) - 1$. ■

Our final three lemmas show that the amortized cost of each MAKE-SET, LINK, and FIND-SET operation is $O(\alpha(n))$. Recall from equation (17.2) that the amortized cost of each operation is its actual cost plus the increase in potential due to the operation.

Lemma 21.11

The amortized cost of each MAKE-SET operation is $O(1)$.

Proof Suppose that the q th operation is MAKE-SET(x). This operation creates node x with rank 0, so that $\phi_q(x) = 0$. No other ranks or potentials change, and so $\Phi_q = \Phi_{q-1}$. Noting that the actual cost of the MAKE-SET operation is $O(1)$ completes the proof. ■

Lemma 21.12

The amortized cost of each LINK operation is $O(\alpha(n))$.

Proof Suppose that the q th operation is LINK(x, y). The actual cost of the LINK operation is $O(1)$. Without loss of generality, suppose that the LINK makes y the parent of x .

To determine the change in potential due to the LINK, we note that the only nodes whose potentials may change are x , y , and the children of y just prior to the operation. We shall show that the only node whose potential can increase due to the LINK is y , and that its increase is at most $\alpha(n)$:

- By Lemma 21.10, any node that is y 's child just before the LINK cannot have its potential increase due to the LINK.
- From the definition of $\phi_q(x)$, we see that, since x was a root just before the q th operation, $\phi_{q-1}(x) = \alpha(n) \cdot x.\text{rank}$. If $x.\text{rank} = 0$, then $\phi_q(x) = \phi_{q-1}(x) = 0$. Otherwise,

$$\begin{aligned} \phi_q(x) &< \alpha(n) \cdot x.\text{rank} \quad (\text{by Corollary 21.9}) \\ &= \phi_{q-1}(x), \end{aligned}$$

and so x 's potential decreases.

- Because y is a root prior to the LINK, $\phi_{q-1}(y) = \alpha(n) \cdot y.rank$. The LINK operation leaves y as a root, and it either leaves y 's rank alone or it increases y 's rank by 1. Therefore, either $\phi_q(y) = \phi_{q-1}(y)$ or $\phi_q(y) = \phi_{q-1}(y) + \alpha(n)$.

The increase in potential due to the LINK operation, therefore, is at most $\alpha(n)$. The amortized cost of the LINK operation is $O(1) + \alpha(n) = O(\alpha(n))$. ■

Lemma 21.13

The amortized cost of each FIND-SET operation is $O(\alpha(n))$.

Proof Suppose that the q th operation is a FIND-SET and that the find path contains s nodes. The actual cost of the FIND-SET operation is $O(s)$. We shall show that no node's potential increases due to the FIND-SET and that at least $\max(0, s - (\alpha(n) + 2))$ nodes on the find path have their potential decrease by at least 1.

To see that no node's potential increases, we first appeal to Lemma 21.10 for all nodes other than the root. If x is the root, then its potential is $\alpha(n) \cdot x.rank$, which does not change.

Now we show that at least $\max(0, s - (\alpha(n) + 2))$ nodes have their potential decrease by at least 1. Let x be a node on the find path such that $x.rank > 0$ and x is followed somewhere on the find path by another node y that is not a root, where $\text{level}(y) = \text{level}(x)$ just before the FIND-SET operation. (Node y need not immediately follow x on the find path.) All but at most $\alpha(n) + 2$ nodes on the find path satisfy these constraints on x . Those that do not satisfy them are the first node on the find path (if it has rank 0), the last node on the path (i.e., the root), and the last node w on the path for which $\text{level}(w) = k$, for each $k = 0, 1, 2, \dots, \alpha(n) - 1$.

Let us fix such a node x , and we shall show that x 's potential decreases by at least 1. Let $k = \text{level}(x) = \text{level}(y)$. Just prior to the path compression caused by the FIND-SET, we have

$$\begin{aligned} x.p.rank &\geq A_k^{(\text{iter}(x))}(x.rank) && \text{(by definition of iter}(x)) \text{ ,} \\ y.p.rank &\geq A_k(y.rank) && \text{(by definition of level}(y)) \text{ ,} \\ y.rank &\geq x.p.rank && \text{(by Corollary 21.5 and because} \\ &&& \text{y follows x on the find path) .} \end{aligned}$$

Putting these inequalities together and letting i be the value of $\text{iter}(x)$ before path compression, we have

$$\begin{aligned} y.p.rank &\geq A_k(y.rank) \\ &\geq A_k(x.p.rank) && \text{(because } A_k(j) \text{ is strictly increasing)} \\ &\geq A_k(A_k^{(\text{iter}(x))}(x.rank)) \\ &= A_k^{(i+1)}(x.rank) . \end{aligned}$$

Because path compression will make x and y have the same parent, we know that after path compression, $x.p.rank = y.p.rank$ and that the path compression does not decrease $y.p.rank$. Since $x.rank$ does not change, after path compression we have that $x.p.rank \geq A_k^{(i+1)}(x.rank)$. Thus, path compression will cause either $iter(x)$ to increase (to at least $i + 1$) or $level(x)$ to increase (which occurs if $iter(x)$ increases to at least $x.rank + 1$). In either case, by Lemma 21.10, we have $\phi_q(x) \leq \phi_{q-1}(x) - 1$. Hence, x 's potential decreases by at least 1.

The amortized cost of the FIND-SET operation is the actual cost plus the change in potential. The actual cost is $O(s)$, and we have shown that the total potential decreases by at least $\max(0, s - (\alpha(n) + 2))$. The amortized cost, therefore, is at most $O(s) - (s - (\alpha(n) + 2)) = O(s) - s + O(\alpha(n)) = O(\alpha(n))$, since we can scale up the units of potential to dominate the constant hidden in $O(s)$. ■

Putting the preceding lemmas together yields the following theorem.

Theorem 21.14

A sequence of m MAKE-SET, UNION, and FIND-SET operations, n of which are MAKE-SET operations, can be performed on a disjoint-set forest with union by rank and path compression in worst-case time $O(m \alpha(n))$.

Proof Immediate from Lemmas 21.7, 21.11, 21.12, and 21.13. ■

Exercises

21.4-1

Prove Lemma 21.4.

21.4-2

Prove that every node has rank at most $\lfloor \lg n \rfloor$.

21.4-3

In light of Exercise 21.4-2, how many bits are necessary to store $x.rank$ for each node x ?

21.4-4

Using Exercise 21.4-2, give a simple proof that operations on a disjoint-set forest with union by rank but without path compression run in $O(m \lg n)$ time.

21.4-5

Professor Dante reasons that because node ranks increase strictly along a simple path to the root, node levels must monotonically increase along the path. In other

words, if $x.rank > 0$ and $x.p$ is not a root, then $level(x) \leq level(x.p)$. Is the professor correct?

21.4-6 ★

Consider the function $\alpha'(n) = \min \{k : A_k(1) \geq \lg(n + 1)\}$. Show that $\alpha'(n) \leq 3$ for all practical values of n and, using Exercise 21.4-2, show how to modify the potential-function argument to prove that we can perform a sequence of m MAKE-SET, UNION, and FIND-SET operations, n of which are MAKE-SET operations, on a disjoint-set forest with union by rank and path compression in worst-case time $O(m \alpha'(n))$.

Problems

21-1 Off-line minimum

The *off-line minimum problem* asks us to maintain a dynamic set T of elements from the domain $\{1, 2, \dots, n\}$ under the operations INSERT and EXTRACT-MIN. We are given a sequence S of n INSERT and m EXTRACT-MIN calls, where each key in $\{1, 2, \dots, n\}$ is inserted exactly once. We wish to determine which key is returned by each EXTRACT-MIN call. Specifically, we wish to fill in an array *extracted*[1.. m], where for $i = 1, 2, \dots, m$, *extracted*[i] is the key returned by the i th EXTRACT-MIN call. The problem is “off-line” in the sense that we are allowed to process the entire sequence S before determining any of the returned keys.

- a.* In the following instance of the off-line minimum problem, each operation INSERT(i) is represented by the value of i and each EXTRACT-MIN is represented by the letter E:

4, 8, E, 3, E, 9, 2, 6, E, E, E, 1, 7, E, 5 .

Fill in the correct values in the *extracted* array.

To develop an algorithm for this problem, we break the sequence S into homogeneous subsequences. That is, we represent S by

$I_1, E, I_2, E, I_3, \dots, I_m, E, I_{m+1}$,

where each E represents a single EXTRACT-MIN call and each I_j represents a (possibly empty) sequence of INSERT calls. For each subsequence I_j , we initially place the keys inserted by these operations into a set K_j , which is empty if I_j is empty. We then do the following:

OFF-LINE-MINIMUM(m, n)

```

1  for  $i = 1$  to  $n$ 
2      determine  $j$  such that  $i \in K_j$ 
3      if  $j \neq m + 1$ 
4           $extracted[j] = i$ 
5          let  $l$  be the smallest value greater than  $j$ 
              for which set  $K_l$  exists
6           $K_l = K_j \cup K_l$ , destroying  $K_j$ 
7  return  $extracted$ 

```

- b.* Argue that the array *extracted* returned by OFF-LINE-MINIMUM is correct.
- c.* Describe how to implement OFF-LINE-MINIMUM efficiently with a disjoint-set data structure. Give a tight bound on the worst-case running time of your implementation.

21-2 Depth determination

In the *depth-determination problem*, we maintain a forest $\mathcal{F} = \{T_i\}$ of rooted trees under three operations:

MAKE-TREE(v) creates a tree whose only node is v .

FIND-DEPTH(v) returns the depth of node v within its tree.

GRAFT(r, v) makes node r , which is assumed to be the root of a tree, become the child of node v , which is assumed to be in a different tree than r but may or may not itself be a root.

- a.* Suppose that we use a tree representation similar to a disjoint-set forest: $v.p$ is the parent of node v , except that $v.p = v$ if v is a root. Suppose further that we implement GRAFT(r, v) by setting $r.p = v$ and FIND-DEPTH(v) by following the find path up to the root, returning a count of all nodes other than v encountered. Show that the worst-case running time of a sequence of m MAKE-TREE, FIND-DEPTH, and GRAFT operations is $\Theta(m^2)$.

By using the union-by-rank and path-compression heuristics, we can reduce the worst-case running time. We use the disjoint-set forest $\mathcal{S} = \{S_i\}$, where each set S_i (which is itself a tree) corresponds to a tree T_i in the forest \mathcal{F} . The tree structure within a set S_i , however, does not necessarily correspond to that of T_i . In fact, the implementation of S_i does not record the exact parent-child relationships but nevertheless allows us to determine any node's depth in T_i .

The key idea is to maintain in each node v a "pseudodistance" $v.d$, which is defined so that the sum of the pseudodistances along the simple path from v to the

root of its set S_i equals the depth of v in T_i . That is, if the simple path from v to its root in S_i is v_0, v_1, \dots, v_k , where $v_0 = v$ and v_k is S_i 's root, then the depth of v in T_i is $\sum_{j=0}^k v_j.d$.

- b. Give an implementation of MAKE-TREE.
- c. Show how to modify FIND-SET to implement FIND-DEPTH. Your implementation should perform path compression, and its running time should be linear in the length of the find path. Make sure that your implementation updates pseudodistances correctly.
- d. Show how to implement GRAFT(r, v), which combines the sets containing r and v , by modifying the UNION and LINK procedures. Make sure that your implementation updates pseudodistances correctly. Note that the root of a set S_i is not necessarily the root of the corresponding tree T_i .
- e. Give a tight bound on the worst-case running time of a sequence of m MAKE-TREE, FIND-DEPTH, and GRAFT operations, n of which are MAKE-TREE operations.

21-3 Tarjan's off-line least-common-ancestors algorithm

The *least common ancestor* of two nodes u and v in a rooted tree T is the node w that is an ancestor of both u and v and that has the greatest depth in T . In the *off-line least-common-ancestors problem*, we are given a rooted tree T and an arbitrary set $P = \{\{u, v\}\}$ of unordered pairs of nodes in T , and we wish to determine the least common ancestor of each pair in P .

To solve the off-line least-common-ancestors problem, the following procedure performs a tree walk of T with the initial call $\text{LCA}(T.\text{root})$. We assume that each node is colored WHITE prior to the walk.

LCA(u)

```

1  MAKE-SET( $u$ )
2  FIND-SET( $u$ ).ancestor =  $u$ 
3  for each child  $v$  of  $u$  in  $T$ 
4      LCA( $v$ )
5      UNION( $u, v$ )
6      FIND-SET( $u$ ).ancestor =  $u$ 
7   $u$ .color = BLACK
8  for each node  $v$  such that  $\{u, v\} \in P$ 
9      if  $v$ .color == BLACK
10         print "The least common ancestor of"
               $u$  "and"  $v$  "is" FIND-SET( $v$ ).ancestor
```

- a.* Argue that line 10 executes exactly once for each pair $\{u, v\} \in P$.
- b.* Argue that at the time of the call $\text{LCA}(u)$, the number of sets in the disjoint-set data structure equals the depth of u in T .
- c.* Prove that LCA correctly prints the least common ancestor of u and v for each pair $\{u, v\} \in P$.
- d.* Analyze the running time of LCA , assuming that we use the implementation of the disjoint-set data structure in Section 21.3.

Chapter notes

Many of the important results for disjoint-set data structures are due at least in part to R. E. Tarjan. Using aggregate analysis, Tarjan [328, 330] gave the first tight upper bound in terms of the very slowly growing inverse $\hat{\alpha}(m, n)$ of Ackermann's function. (The function $A_k(j)$ given in Section 21.4 is similar to Ackermann's function, and the function $\alpha(n)$ is similar to the inverse. Both $\alpha(n)$ and $\hat{\alpha}(m, n)$ are at most 4 for all conceivable values of m and n .) An $O(m \lg^* n)$ upper bound was proven earlier by Hopcroft and Ullman [5, 179]. The treatment in Section 21.4 is adapted from a later analysis by Tarjan [332], which is in turn based on an analysis by Kozen [220]. Harfst and Reingold [161] give a potential-based version of Tarjan's earlier bound.

Tarjan and van Leeuwen [333] discuss variants on the path-compression heuristic, including "one-pass methods," which sometimes offer better constant factors in their performance than do two-pass methods. As with Tarjan's earlier analyses of the basic path-compression heuristic, the analyses by Tarjan and van Leeuwen are aggregate. Harfst and Reingold [161] later showed how to make a small change to the potential function to adapt their path-compression analysis to these one-pass variants. Gabow and Tarjan [121] show that in certain applications, the disjoint-set operations can be made to run in $O(m)$ time.

Tarjan [329] showed that a lower bound of $\Omega(m \hat{\alpha}(m, n))$ time is required for operations on any disjoint-set data structure satisfying certain technical conditions. This lower bound was later generalized by Fredman and Saks [113], who showed that in the worst case, $\Omega(m \hat{\alpha}(m, n))$ ($\lg n$)-bit words of memory must be accessed.