

Graph Traversal

Graphs are one of the unifying themes of computer science—an abstract representation that describes the organization of transportation systems, human interactions, and telecommunication networks. That so many different structures can be modeled using a single formalism is a source of great power to the educated programmer.

More precisely, a graph $G = (V, E)$ consists of a set of *vertices* V together with a set E of vertex pairs or *edges*. Graphs are important because they can be used to represent essentially *any* relationship. For example, graphs can model a network of roads, with cities as vertices and roads between cities as edges, as shown in Figure 5.1. Electronic circuits can also be modeled as graphs, with junctions as vertices and components as edges.

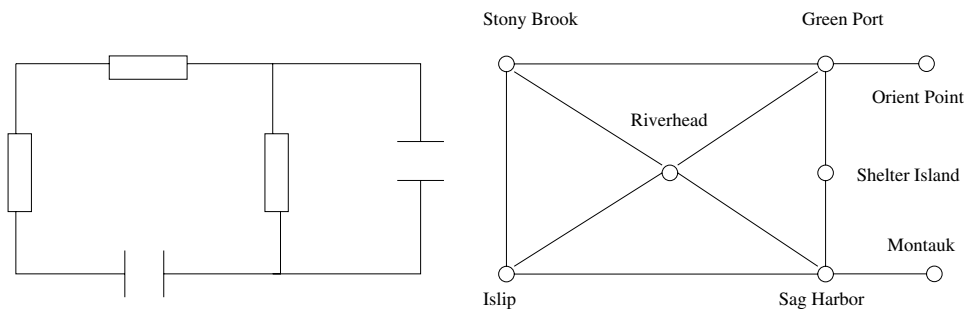

Figure 5.1: Modeling road networks and electronic circuits as graphs

The key to solving many algorithmic problems is to think of them in terms of graphs. Graph theory provides a language for talking about the properties of relationships, and it is amazing how often messy applied problems have a simple description and solution in terms of classical graph properties.

Designing truly novel graph algorithms is a very difficult task. The key to using graph algorithms effectively in applications lies in correctly modeling your problem so you can take advantage of existing algorithms. Becoming familiar with many different algorithmic graph *problems* is more important than understanding the details of particular graph algorithms, particularly since Part II of this book will point you to an implementation as soon as you know the name of your problem.

Here we present basic data structures and traversal operations for graphs, which will enable you to cobble together solutions for basic graph problems. Chapter 6 will present more advanced graph algorithms that find minimum spanning trees, shortest paths, and network flows, but we stress the primary importance of correctly modeling your problem. Time spent browsing through the catalog now will leave you better informed of your options when a real job arises.

5.1 Flavors of Graphs

A graph $G = (V, E)$ is defined on a set of *vertices* V , and contains a set of *edges* E of ordered or unordered pairs of vertices from V . In modeling a road network, the vertices may represent the cities or junctions, certain pairs of which are connected by roads/edges. In analyzing the source code of a computer program, the vertices may represent lines of code, with an edge connecting lines x and y if y is the next statement executed after x . In analyzing human interactions, the vertices typically represent people, with edges connecting pairs of related souls.

Several fundamental properties of graphs impact the choice of the data structures used to represent them and algorithms available to analyze them. The first step in any graph problem is determining the flavors of graphs you are dealing with:

- *Undirected vs. Directed* – A graph $G = (V, E)$ is *undirected* if edge $(x, y) \in E$ implies that (y, x) is also in E . If not, we say that the graph is *directed*. Road networks *between* cities are typically undirected, since any large road has lanes going in both directions. Street networks *within* cities are almost always directed, because there are at least a few one-way streets lurking somewhere. Program-flow graphs are typically directed, because the execution flows from one line into the next and changes direction only at branches. Most graphs of graph-theoretic interest are undirected.
- *Weighted vs. Unweighted* – Each edge (or vertex) in a *weighted* graph G is assigned a numerical value, or weight. The edges of a road network graph might be weighted with their length, drive-time, or speed limit, depending upon the

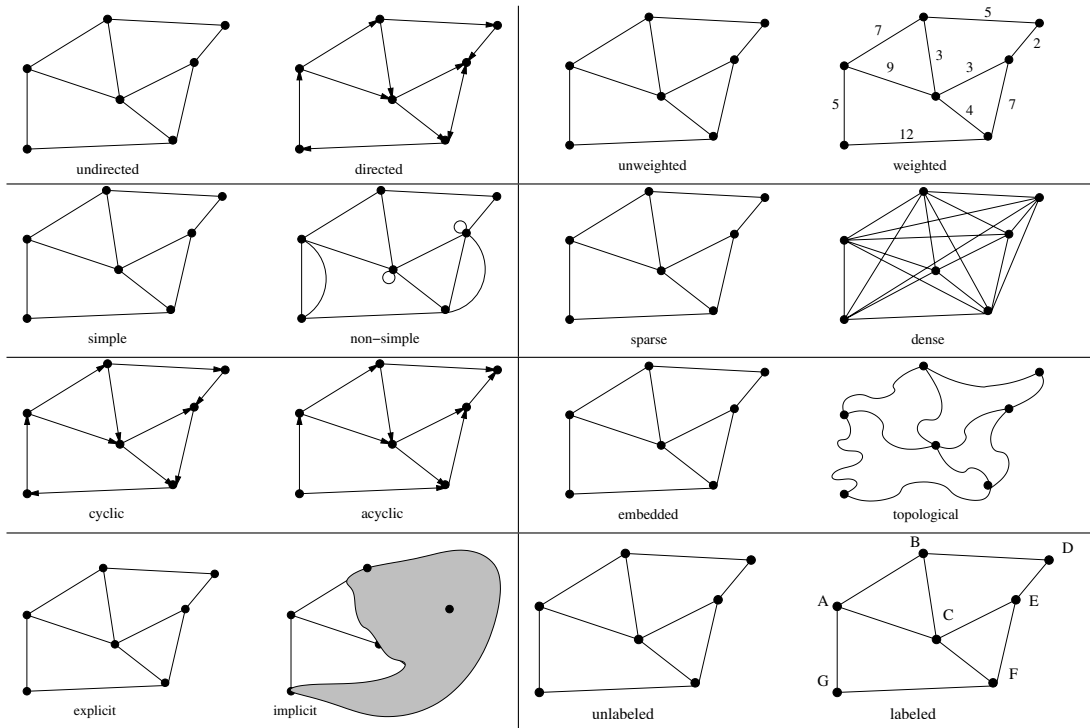

Figure 5.2: Important properties / flavors of graphs

application. In *unweighted* graphs, there is no cost distinction between various edges and vertices.

The difference between weighted and unweighted graphs becomes particularly apparent in finding the shortest path between two vertices. For unweighted graphs, the shortest path must have the fewest number of edges, and can be found using a breadth-first search as discussed in this chapter. Shortest paths in weighted graphs requires more sophisticated algorithms, as discussed in Chapter 6.

- *Simple vs. Non-simple* – Certain types of edges complicate the task of working with graphs. A *self-loop* is an edge (x, x) involving only one vertex. An edge (x, y) is a *multiedge* if it occurs more than once in the graph.

Both of these structures require special care in implementing graph algorithms. Hence any graph that avoids them is called *simple*.

- *Sparse vs. Dense*: Graphs are *sparse* when only a small fraction of the possible vertex pairs ($\binom{n}{2}$ for a simple, undirected graph on n vertices) actually have edges defined between them. Graphs where a large fraction of the vertex pairs define edges are called *dense*. There is no official boundary between what is called sparse and what is called dense, but typically dense graphs have a quadratic number of edges, while sparse graphs are linear in size.

Sparse graphs are usually sparse for application-specific reasons. Road networks must be sparse graphs because of road junctions. The most ghastly intersection I've ever heard of was the endpoint of only seven different roads. Junctions of electrical components are similarly limited to the number of wires that can meet at a point, perhaps except for power and ground.

- *Cyclic vs. Acyclic* – An *acyclic* graph does not contain any cycles. *Trees* are connected, acyclic undirected graphs. Trees are the simplest interesting graphs, and are inherently recursive structures because cutting any edge leaves two smaller trees.

Directed acyclic graphs are called *DAGs*. They arise naturally in scheduling problems, where a directed edge (x, y) indicates that activity x must occur before y . An operation called *topological sorting* orders the vertices of a DAG to respect these precedence constraints. Topological sorting is typically the first step of any algorithm on a DAG, as will be discussed in Section 5.10.1 (page 179).

- *Embedded vs. Topological* – A graph is *embedded* if the vertices and edges are assigned geometric positions. Thus, any drawing of a graph is an *embedding*, which may or may not have algorithmic significance.

Occasionally, the structure of a graph is completely defined by the geometry of its embedding. For example, if we are given a collection of points in the plane, and seek the minimum cost tour visiting all of them (i.e., the traveling salesman problem), the underlying topology is the *complete graph* connecting each pair of vertices. The weights are typically defined by the Euclidean distance between each pair of points.

Grids of points are another example of topology from geometry. Many problems on an $n \times m$ grid involve walking between neighboring points, so the edges are implicitly defined from the geometry.

- *Implicit vs. Explicit* – Certain graphs are not explicitly constructed and then traversed, but built as we use them. A good example is in backtrack search. The vertices of this implicit search graph are the states of the search vector, while edges link pairs of states that can be directly generated from each other. Because you do not have to store the entire graph, it is often easier to work with an implicit graph than explicitly construct it prior to analysis.

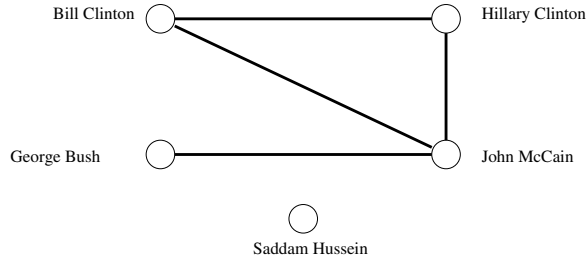

Figure 5.3: A portion of the friendship graph

- *Labeled vs. Unlabeled* – Each vertex is assigned a unique name or identifier in a *labeled* graph to distinguish it from all other vertices. In *unlabeled* graphs, no such distinctions have been made.

Graphs arising in applications are often naturally and meaningfully labeled, such as city names in a transportation network. A common problem is that of *isomorphism testing*—determining whether the topological structure of two graphs are identical if we ignore any labels. Such problems are typically solved using backtracking, by trying to assign each vertex in each graph a label such that the structures are identical.

5.1.1 The Friendship Graph

To demonstrate the importance of proper modeling, let us consider a graph where the vertices are people, and there is an edge between two people if and only if they are friends. Such graphs are called *social networks* and are well defined on any set of people—be they the people in your neighborhood, at your school/business, or even spanning the entire world. An entire science analyzing social networks has sprung up in recent years, because many interesting aspects of people and their behavior are best understood as properties of this friendship graph.

Most of the graphs that one encounters in real life are sparse. The friendship graph is good example. Even the most gregarious person on earth knows an insignificant fraction of the world’s population.

We use this opportunity to demonstrate the graph theory terminology described above. “Talking the talk” proves to be an important part of “walking the walk”:

- *If I am your friend, does that mean you are my friend?* – This question really asks whether the graph is directed. A graph is *undirected* if edge (x, y) always implies (y, x) . Otherwise, the graph is said to be *directed*. The “heard-of” graph is directed, since I have heard of many famous people who have never heard of me! The “had-sex-with” graph is presumably undirected, since the critical operation always requires a partner. I’d like to think that the “friendship” graph is also an undirected graph.

- *How close a friend are you?* – In *weighted* graphs, each edge has an associated numerical attribute. We could model the strength of a friendship by associating each edge with an appropriate value, perhaps from -10 (enemies) to 10 (blood brothers). The edges of a road network graph might be weighted with their length, drive-time, or speed limit, depending upon the application. A graph is said to be *unweighted* if all edges are assumed to be of equal weight.
- *Am I my own friend?* – This question addresses whether the graph is *simple*, meaning it contains no loops and no multiple edges. An edge of the form (x, x) is said to be a *loop*. Sometimes people are friends in several different ways. Perhaps x and y were college classmates and now work together at the same company. We can model such relationships using *multiedges*—multiple edges (x, y) perhaps distinguished by different labels.

Simple graphs really are often simpler to work with in practice. Therefore, we might be better off declaring that no one is their own friend.

- *Who has the most friends?* – The *degree* of a vertex is the number of edges adjacent to it. The most popular person defines the vertex of highest degree in the friendship graph. Remote hermits are associated with degree-zero vertices.

In *dense* graphs, most vertices have high degrees, as opposed to *sparse* graphs with relatively few edges. In a *regular graph*, each vertex has exactly the same degree. A regular friendship graph is truly the ultimate in social-ism.

- *Do my friends live near me?* – Social networks are not divorced from geography. Many of your friends are your friends only because they happen to live near you (e.g., neighbors) or used to live near you (e.g., college roommates).

Thus, a full understanding of social networks requires an *embedded* graph, where each vertex is associated with the point on this world where they live. This geographic information may not be explicitly encoded, but the fact that the graph is inherently embedded in the plane shapes our interpretation of any analysis.

- *Oh, you also know her?* – Social networking services such as Myspace and LinkedIn are built on the premise of *explicitly* defining the links between members and their member-friends. Such graphs consist of directed edges from person/vertex x professing his friendship to person/vertex y .

That said, the complete friendship graph of the world is represented *implicitly*. Each person knows who their friends are, but cannot find out about other people's friendships except by asking them. The "six degrees of separation" theory argues that there is a short path linking every two people in the world (e.g., Skiena and the President) but offers us no help in actually finding this path. The shortest such path I know of contains three hops (Steven Skiena \rightarrow Bob McGrath \rightarrow John Marberger \rightarrow George W. Bush), but there could

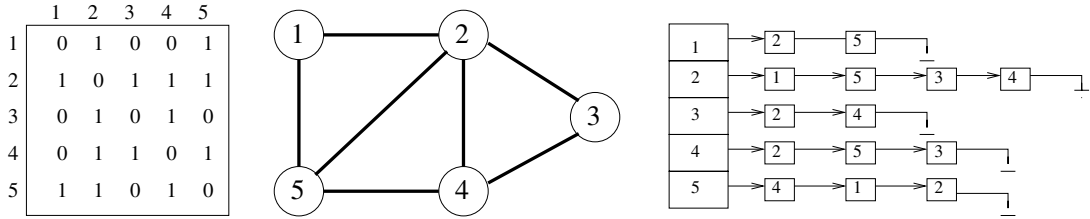

Figure 5.4: The adjacency matrix and adjacency list of a given graph

be a shorter one (say, if he went to college with my dentist). The friendship graph is stored implicitly, so I have no way of easily checking.

- *Are you truly an individual, or just one of the faceless crowd?* – This question boils down to whether the friendship graph is labeled or unlabeled. Does each vertex have a name/label which reflects its identity, and is this label important for our analysis?

Much of the study of social networks is unconcerned with labels on graphs. Often the index number given a vertex in the graph data structure serves as its label, perhaps for convenience or the need for anonymity. You may assert that you are a name, not a number—but try protesting to the guy who implements the algorithm. Someone studying how an infectious disease spreads through a graph may label each vertex with whether the person is healthy or sick, it being irrelevant what their name is.

Take-Home Lesson: Graphs can be used to model a wide variety of structures and relationships. Graph-theoretic terminology gives us a language to talk about them.

5.2 Data Structures for Graphs

Selecting the right graph data structure can have an enormous impact on performance. Your two basic choices are adjacency matrices and adjacency lists, illustrated in Figure 5.4. We assume the graph $G = (V, E)$ contains n vertices and m edges.

- *Adjacency Matrix:* We can represent G using an $n \times n$ matrix M , where element $M[i, j] = 1$ if (i, j) is an edge of G , and 0 if it isn't. This allows fast answers to the question “is (i, j) in G ?”, and rapid updates for edge insertion and deletion. It may use excessive space for graphs with many vertices and relatively few edges, however.

Comparison	Winner
Faster to test if (x, y) is in graph?	adjacency matrices
Faster to find the degree of a vertex?	adjacency lists
Less memory on small graphs?	adjacency lists $(m + n)$ vs. (n^2)
Less memory on big graphs?	adjacency matrices (a small win)
Edge insertion or deletion?	adjacency matrices $O(1)$ vs. $O(d)$
Faster to traverse the graph?	adjacency lists $\Theta(m + n)$ vs. $\Theta(n^2)$
Better for most problems?	adjacency lists

Figure 5.5: Relative advantages of adjacency lists and matrices.

Consider a graph that represents the street map of Manhattan in New York City. Every junction of two streets will be a vertex of the graph. Neighboring junctions are connected by edges. How big is this graph? Manhattan is basically a grid of 15 avenues each crossing roughly 200 streets. This gives us about 3,000 vertices and 6,000 edges, since each vertex neighbors four other vertices and each edge is shared between two vertices. This modest amount of data should easily and efficiently be stored, yet an adjacency matrix would have $3,000 \times 3,000 = 9,000,000$ cells, almost all of them empty!

There is some potential to save space by packing multiple bits per word or simulating a triangular matrix on undirected graphs. But these methods lose the simplicity that makes adjacency matrices so appealing and, more critically, remain inherently quadratic on sparse graphs.

- *Adjacency Lists:* We can more efficiently represent sparse graphs by using linked lists to store the neighbors adjacent to each vertex. Adjacency lists require pointers but are not frightening once you have experience with linked structures.

Adjacency lists make it harder to verify whether a given edge (i, j) is in G , since we must search through the appropriate list to find the edge. However, it is surprisingly easy to design graph algorithms that avoid any need for such queries. Typically, we sweep through all the edges of the graph in one pass via a breadth-first or depth-first traversal, and update the implications of the current edge as we visit it. Table 5.5 summarizes the tradeoffs between adjacency lists and matrices.

Take-Home Lesson: Adjacency lists are the right data structure for most applications of graphs.

We will use adjacency lists as our primary data structure to represent graphs. We represent a graph using the following data type. For each graph, we keep a

count of the number of vertices, and assign each vertex a unique identification number from 1 to `nvertices`. We represent the edges using an array of linked lists:

```
#define MAXV          1000      /* maximum number of vertices */

typedef struct {
    int y;                    /* adjacency info */
    int weight;              /* edge weight, if any */
    struct edgenode *next;   /* next edge in list */
} edgenode;

typedef struct {
    edgenode *edges[MAXV+1]; /* adjacency info */
    int degree[MAXV+1];     /* outdegree of each vertex */
    int nvertices;          /* number of vertices in graph */
    int nedges;             /* number of edges in graph */
    bool directed;         /* is the graph directed? */
} graph;
```

We represent directed edge (x, y) by an `edgenode` y in x 's adjacency list. The degree field of the `graph` counts the number of meaningful entries for the given vertex. An undirected edge (x, y) appears twice in any adjacency-based graph structure, once as y in x 's list, and once as x in y 's list. The boolean flag `directed` identifies whether the given graph is to be interpreted as directed or undirected.

To demonstrate the use of this data structure, we show how to read a graph from a file. A typical graph format consists of an initial line featuring the number of vertices and edges in the graph, followed by a listing of the edges at one vertex pair per line.

```
initialize_graph(graph *g, bool directed)
{
    int i;                    /* counter */

    g -> nvertices = 0;
    g -> nedges = 0;
    g -> directed = directed;

    for (i=1; i<=MAXV; i++) g->degree[i] = 0;
    for (i=1; i<=MAXV; i++) g->edges[i] = NULL;
}
```

Actually reading the graph requires inserting each edge into this structure:

```

read_graph(graph *g, bool directed)
{
    int i;                               /* counter */
    int m;                               /* number of edges */
    int x, y;                            /* vertices in edge (x,y) */

    initialize_graph(g, directed);

    scanf("%d %d",&(g->nvertices),&m);

    for (i=1; i<=m; i++) {
        scanf("%d %d",&x,&y);
        insert_edge(g,x,y,directed);
    }
}

```

The critical routine is `insert_edge`. The new `edgenode` is inserted at the beginning of the appropriate adjacency list, since order doesn't matter. We parameterize our insertion with the `directed` Boolean flag, to identify whether we need to insert two copies of each edge or only one. Note the use of recursion to solve this problem:

```

insert_edge(graph *g, int x, int y, bool directed)
{
    edgenode *p;                          /* temporary pointer */

    p = malloc(sizeof(edgenode)); /* allocate edgenode storage */

    p->weight = NULL;
    p->y = y;
    p->next = g->edges[x];

    g->edges[x] = p;                       /* insert at head of list */

    g->degree[x] ++;

    if (directed == FALSE)
        insert_edge(g,y,x,TRUE);
    else
        g->nedges ++;
}

```

Printing the associated graph is just a matter of two nested loops, one through vertices, the other through adjacent edges:

```

print_graph(graph *g)
{
    int i;                                /* counter */
    edgenode *p;                          /* temporary pointer */

    for (i=1; i<=g->nvertices; i++) {
        printf("%d: ",i);
        p = g->edges[i];
        while (p != NULL) {
            printf(" %d",p->y);
            p = p->next;
        }
        printf("\n");
    }
}

```

It is a good idea to use a well-designed graph data type as a model for building your own, or even better as the foundation for your application. We recommend LEDA (see Section 19.1.1 (page 658)) or Boost (see Section 19.1.3 (page 659)) as the best-designed general-purpose graph data structures currently available. They may be more powerful (and hence somewhat slower/larger) than you need, but they do so many things right that you are likely to lose most of the potential do-it-yourself benefits through clumsiness.

5.3 War Story: I was a Victim of Moore's Law

I am the author of a popular library of graph algorithms called *Combinatorica* (see www.combinatorica.com), which runs under the computer algebra system *Mathematica*. Efficiency is a great challenge in *Mathematica*, due to its applicative model of computation (it does not support constant-time write operations to arrays) and the overhead of interpretation (as opposed to compilation). *Mathematica* code is typically 1,000 to 5,000 times slower than C code.

Such slow downs can be a tremendous performance hit. Even worse, *Mathematica* was a memory hog, needing a then-outrageous 4MB of main memory to run effectively when I completed *Combinatorica* in 1990. Any computation on large structures was doomed to thrash in virtual memory. In such an environment, my graph package could only hope to work effectively on *very* small graphs.

One design decision I made as a result was to use adjacency matrices as the basic *Combinatorica* graph data structure instead of lists. This may sound peculiar. If pressed for memory, wouldn't it pay to use adjacency lists and conserve every last byte? Yes, but the answer is not so simple for very small graphs. An adjacency list representation of a weighted n -vertex, m -edge graph should use about $n+2m$ words to represent; the $2m$ comes from storing the endpoint and weight components of

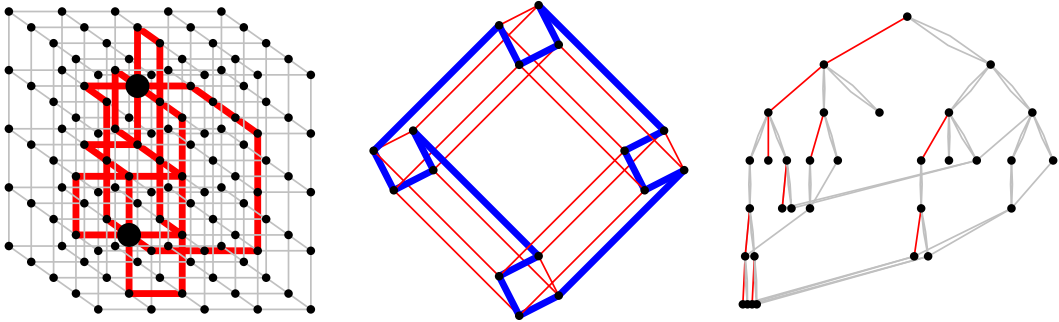

Figure 5.6: Representative *Combinatorica* graphs: edge-disjoint paths (left), Hamiltonian cycle in a hypercube (center), animated depth-first search tree traversal (right)

each edge. Thus, the space advantages of adjacency lists kick in when $n + 2m$ is substantially smaller than n^2 . The adjacency matrix is still manageable in size for $n \leq 100$ and, of course, half the size of adjacency lists on dense graphs.

My more immediate concern was dealing with the overhead of using a slow interpreted language. Check out the benchmarks reported in Table 5.1. Two particularly complex but polynomial-time problems on 9 and 16 vertex graphs took several minutes to complete on my desktop machine in 1990! The quadratic-sized data structure certainly could not have had much impact on these running times, since 9×9 equals only 81. From experience, I knew the *Mathematica* programming language handled better to regular structures like adjacency matrices better than irregular-sized adjacency lists.

Still, *Combinatorica* proved to be a very good thing despite these performance problems. Thousands of people have used my package to do all kinds of interesting things with graphs. *Combinatorica* was never intended to be a high-performance algorithms library. Most users quickly realized that computations on large graphs were out of the question, but were eager to take advantage of *Combinatorica* as a mathematical research tool and prototyping environment. Everyone was happy.

But over the years, my users started asking why it took so long to do a modest-sized graph computation. The mystery wasn't that my program was slow, because it had always been slow. The question was why did it take so many years for people to figure this out?

Approximate year command/machine	1990 Sun-3	1991 Sun-4	1998 Sun-5	2000 Ultra 5	2004 SunBlade
PlanarQ[GridGraph[4,4]]	234.10	69.65	27.50	3.60	0.40
Length[Partitions[30]]	289.85	73.20	24.40	3.44	1.58
VertexConnectivity[GridGraph[3,3]]	239.67	47.76	14.70	2.00	0.91
RandomPartition[1000]	831.68	267.5	22.05	3.12	0.87

Table 5.1: Old *Combinatorica* benchmarks on low-end Sun workstations, from 1990 to today, (running time in seconds)

The reason is that computers keep doubling in speed every two years or so. People's *expectation* of how long something should take moves in concert with these technology improvements. Partially because of *Combinatorica*'s dependence on a quadratic-size graph data structure, it didn't scale as well as it should on sparse graphs.

As the years rolled on, user demands become more insistent. *Combinatorica* needed to be updated. My collaborator, Sriram Pemmaraju, rose to the challenge. We (mostly he) completely rewrote *Combinatorica* to take advantage of faster graph data structures ten years after the initial version.

The new *Combinatorica* uses a list of edges data structure for graphs, largely motivated by increased efficiency. Edge lists are linear in the size of the graph (edges plus vertices), just like adjacency lists. This makes a huge difference on most graph related functions—for large enough graphs. The improvement is most dramatic in “fast” graph algorithms—those that run in linear or near linear-time, such as graph traversal, topological sort, and finding connected/biconnected components. The implications of this change is felt throughout the package in running time improvements and memory savings. *Combinatorica* can now work with graphs that are about 50-100 times larger than graphs that the old package could deal with.

Figure 5.7(l) plots the running time of the `MinimumSpanningTree` functions for both *Combinatorica* versions. The test graphs were sparse (grid graphs), designed to highlight the difference between the two data structures. Yes, the new version is *much* faster, but note that the difference only becomes important for graphs larger than the old *Combinatorica* was designed for. However, the relative difference in run time keeps growing with increasing n . Figure 5.7(r) plots the ratio of the running times as a function of graph size. The difference between linear size and quadratic size is asymptotic, so the consequences become ever more important as n gets larger.

What is the weird bump in running times that occurs around $n \approx 250$? This likely reflects a transition between levels of the memory hierarchy. Such bumps are not uncommon in today's complex computer systems. Cache performance in data structure design should be an important but not overriding consideration.

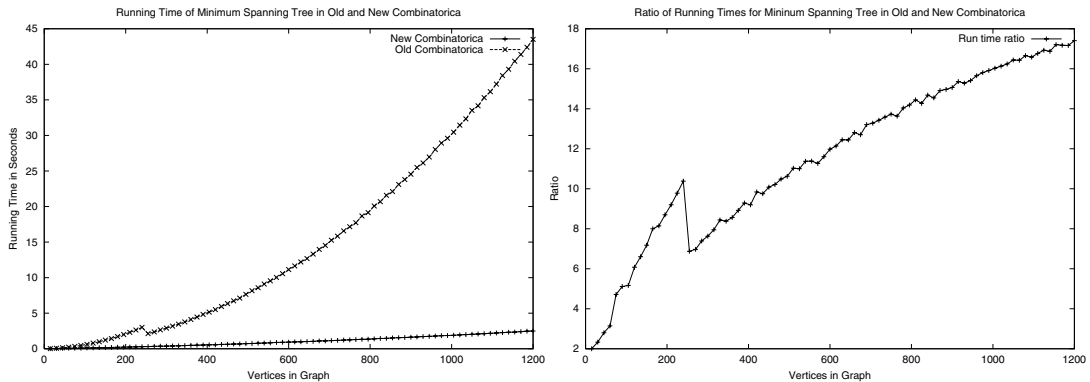

Figure 5.7: Performance comparison between old and new *Combinatorica*: absolute running times (l), and the ratio of these times (r).

The asymptotic gains due to adjacency lists more than trumped any impact of the cache.

Two main lessons can be taken away from our experience developing *Combinatorica*:

- *To make a program run faster, just wait* – Sophisticated hardware eventually slithers down to everybody. We observe a speedup of more than 200-fold for the original version of *Combinatorica* as a consequence of 15 years of faster hardware. In this context, the further speedups we obtained from upgrading the package become particularly dramatic.
- *Asymptotics eventually do matter* – It was my mistake not to anticipate future developments in technology. While no one has a crystal ball, it is fairly safe to say that future computers will have more memory and run faster than today's. This gives an edge to asymptotically more efficient algorithms/data structures, even if their performance is close on today's instances. If the implementation complexity is not substantially greater, play it safe and go with the better algorithm.

5.4 War Story: Getting the Graph

“It takes five minutes just to *read* the data. We will *never* have time to make it do something interesting.”

The young graduate student was bright and eager, but green to the power of data structures. She would soon come to appreciate their power.

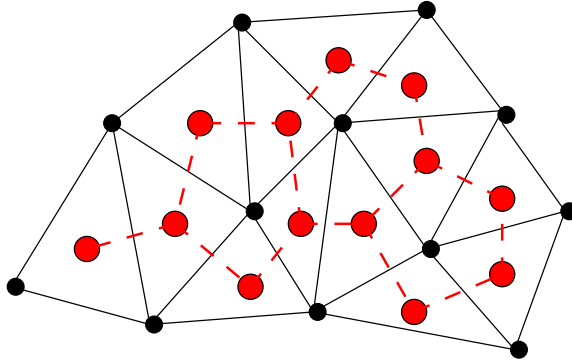

Figure 5.8: The dual graph (dashed lines) of a triangulation

As described in a previous war story (see Section 3.6 (page 85)), we were experimenting with algorithms to extract triangular strips for the fast rendering of triangulated surfaces. The task of finding a small number of strips that cover each triangle in a mesh could be modeled as a graph problem. The graph has a vertex for every *triangle* of the mesh, with an edge between every pair of vertices representing adjacent triangles. This *dual graph* representation (see Figure 5.8) captures all the information needed to partition the triangulation into triangle strips.

The first step in crafting a program that constructs a good set of strips was to build the dual graph of the triangulation. This I sent the student off to do. A few days later, she came back and announced that it took over five CPU minutes just to construct this dual graph of a few thousand triangles.

“Nonsense!” I proclaimed. “You must be doing something very wasteful in building the graph. What format is the data in?”

“Well, it starts out with a list of the 3D coordinates of the vertices used in the model and then follows with a list of triangles. Each triangle is described by a list of three indices into the vertex coordinates. Here is a small example:”

```

VERTICES 4
0.000000 240.000000 0.000000
204.000000 240.000000 0.000000
204.000000 0.000000 0.000000
0.000000 0.000000 0.000000
TRIANGLES 2
0 1 3
1 2 3

```

“I see. So the first triangle uses all but the third point, since all the indices start from zero. The two triangles must share an edge formed by points 1 and 3.”

“Yeah, that’s right,” she confirmed.

“OK. Now tell me how you built your dual graph from this file.”

“Well, I can ignore the vertex information once I know how many vertices there are. The geometric position of the points doesn’t affect the structure of the graph. My dual graph is going to have as many vertices as the number of triangles. I set up an adjacency list data structure with that many vertices. As I read in each triangle, I compare it to each of the others to check whether it has two end points in common. If it does, I add an edge from the new triangle to this one.”

I started to sputter. “But *that’s* your problem right there! You are comparing each triangle against every other triangle, so that constructing the dual graph will be quadratic in the number of triangles. Reading the input graph should take linear time!”

“I’m not comparing every triangle against every other triangle. On average, it only tests against half or a third of the triangles.”

“Swell. But that still leaves us with an $O(n^2)$ algorithm. That is much too slow.”

She stood her ground. “Well, don’t just complain. Help me fix it!”

Fair enough. I started to think. We needed some quick method to screen away most of the triangles that would not be adjacent to the new triangle (i, j, k) . What we really needed was a separate list of all the triangles that go through each of the points i , j , and k . By Euler’s formula for planar graphs, the average point is incident on less than six triangles. This would compare each new triangle against fewer than twenty others, instead of most of them.

“We are going to need a data structure consisting of an array with one element for every vertex in the original data set. This element is going to be a list of all the triangles that pass through that vertex. When we read in a new triangle, we will look up the three relevant lists in the array and compare each of these against the new triangle. Actually, only two of the three lists need be tested, since any adjacent triangles will share two points in common. We will add an adjacency to our graph for every triangle-pair sharing two vertices. Finally, we will add our new triangle to each of the three affected lists, so they will be updated for the next triangle read.”

She thought about this for a while and smiled. “Got it, Chief. I’ll let you know what happens.”

The next day she reported that the graph could be built in seconds, even for much larger models. From here, she went on to build a successful program for extracting triangle strips, as reported in Section 3.6 (page 85).

The take-home lesson is that even elementary problems like initializing data structures can prove to be bottlenecks in algorithm development. Most programs working with large amounts of data have to run in linear or almost linear time. Such tight performance demands leave no room to be sloppy. Once you focus on the need for linear-time performance, an appropriate algorithm or heuristic can usually be found to do the job.

5.5 Traversing a Graph

Perhaps the most fundamental graph problem is to visit every edge and vertex in a graph in a systematic way. Indeed, all the basic bookkeeping operations on graphs (such printing or copying graphs, and converting between alternate representations) are applications of graph traversal.

Mazes are naturally represented by graphs, where each graph vertex denotes a junction of the maze, and each graph edge denotes a hallway in the maze. Thus, any graph traversal algorithm must be powerful enough to get us out of an arbitrary maze. For *efficiency*, we must make sure we don't get trapped in the maze and visit the same place repeatedly. For *correctness*, we must do the traversal in a systematic way to guarantee that we get out of the maze. Our search must take us through every edge and vertex in the graph.

The key idea behind graph traversal is to mark each vertex when we first visit it and keep track of what we have not yet completely explored. Although bread crumbs or unraveled threads have been used to mark visited places in fairy-tale mazes, we will rely on Boolean flags or enumerated types.

Each vertex will exist in one of three states:

- *undiscovered* – the vertex is in its initial, virgin state.
- *discovered* – the vertex has been found, but we have not yet checked out all its incident edges.
- *processed* – the vertex after we have visited all its incident edges.

Obviously, a vertex cannot be *processed* until after we discover it, so the state of each vertex progresses over the course of the traversal from *undiscovered* to *discovered* to *processed*.

We must also maintain a structure containing the vertices that we have discovered but not yet completely processed. Initially, only the single start vertex is considered to be discovered. To completely explore a vertex v , we must evaluate each edge leaving v . If an edge goes to an undiscovered vertex x , we mark x *discovered* and add it to the list of work to do. We ignore an edge that goes to a *processed* vertex, because further contemplation will tell us nothing new about the graph. We can also ignore any edge going to a *discovered* but not *processed* vertex, because the destination already resides on the list of vertices to process.

Each undirected edge will be considered exactly twice, once when each of its endpoints is explored. Directed edges will be considered only once, when exploring the source vertex. Every edge and vertex in the connected component must eventually be visited. Why? Suppose that there exists a vertex u that remains unvisited, whose neighbor v was visited. This neighbor v will eventually be explored, after which we will certainly visit u . Thus, we must find everything that is there to be found.

We describe the mechanics of these traversal algorithms and the significance of the traversal order below.

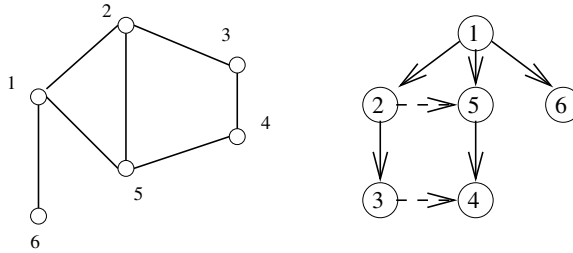

Figure 5.9: An undirected graph and its breadth-first search tree

5.6 Breadth-First Search

The basic breadth-first search algorithm is given below. At some point during the course of a traversal, every node in the graph changes state from *undiscovered* to *discovered*. In a breadth-first search of an undirected graph, we assign a direction to each edge, from the discoverer u to the discovered v . We thus denote u to be the parent of v . Since each node has exactly one parent, except for the root, this defines a tree on the vertices of the graph. This tree, illustrated in Figure 5.9, defines a shortest path from the root to every other node in the tree. This property makes breadth-first search very useful in shortest path problems.

```

BFS( $G, s$ )
  for each vertex  $u \in V[G] - \{s\}$  do
     $state[u] = \text{"undiscovered"}$ 
     $p[u] = nil$ , i.e. no parent is in the BFS tree
   $state[s] = \text{"discovered"}$ 
   $p[s] = nil$ 
   $Q = \{s\}$ 
  while  $Q \neq \emptyset$  do
     $u = dequeue[Q]$ 
    process vertex  $u$  as desired
    for each  $v \in Adj[u]$  do
      process edge  $(u, v)$  as desired
      if  $state[v] = \text{"undiscovered"}$  then
         $state[v] = \text{"discovered"}$ 
         $p[v] = u$ 
        enqueue[ $Q, v$ ]
     $state[u] = \text{"processed"}$ 
  
```

The graph edges that do not appear in the breadth-first search tree also have special properties. For undirected graphs, nontree edges can point only to vertices on the same level as the parent vertex, or to vertices on the level directly below

the parent. These properties follow easily from the fact that each path in the tree must be the shortest path in the graph. For a directed graph, a back-pointing edge (u, v) can exist whenever v lies closer to the root than u does.

Implementation

Our breadth-first search implementation `bfs` uses two Boolean arrays to maintain our knowledge about each vertex in the graph. A vertex is **discovered** the first time we visit it. A vertex is considered **processed** after we have traversed all outgoing edges from it. Thus, each vertex passes from undiscovered to discovered to processed over the course of the search. This information could have been maintained using one enumerated type variable, but we used two Boolean variables instead.

```
bool processed[MAXV+1]; /* which vertices have been processed */
bool discovered[MAXV+1]; /* which vertices have been found */
int parent[MAXV+1]; /* discovery relation */
```

Each vertex is initialized as undiscovered:

```
initialize_search(graph *g)
{
    int i; /* counter */

    for (i=1; i<=g->nvertices; i++) {
        processed[i] = discovered[i] = FALSE;
        parent[i] = -1;
    }
}
```

Once a vertex is discovered, it is placed on a queue. Since we process these vertices in first-in, first-out order, the oldest vertices are expanded first, which are exactly those closest to the root:

```
bfs(graph *g, int start)
{
    queue q; /* queue of vertices to visit */
    int v; /* current vertex */
    int y; /* successor vertex */
    edgenode *p; /* temporary pointer */

    init_queue(&q);
    enqueue(&q, start);
    discovered[start] = TRUE;
```

```
while (empty_queue(&q) == FALSE) {
    v = dequeue(&q);
    process_vertex_early(v);
    processed[v] = TRUE;
    p = g->edges[v];
    while (p != NULL) {
        y = p->y;
        if ((processed[y] == FALSE) || g->directed)
            process_edge(v,y);
        if (discovered[y] == FALSE) {
            enqueue(&q,y);
            discovered[y] = TRUE;
            parent[y] = v;
        }
        p = p->next;
    }
    process_vertex_late(v);
}
}
```

5.6.1 Exploiting Traversal

The exact behavior of `bfs` depends upon the functions `process_vertex_early()`, `process_vertex_late()`, and `process_edge()`. Through these functions, we can customize what the traversal does as it makes its official visit to each edge and each vertex. Initially, we will do all of vertex processing on entry, so `process_vertex_late()` returns without action:

```
process_vertex_late(int v)
{
}
}
```

By setting the active functions to

```
process_vertex_early(int v)
{
    printf("processed vertex %d\n",v);
}

process_edge(int x, int y)
{
    printf("processed edge (%d,%d)\n",x,y);
}
}
```

we print each vertex and edge exactly once. If we instead set `process_edge` to

```
process_edge(int x, int y)
{
    nedges = nedges + 1;
}
```

we get an accurate count of the number of edges. Different algorithms perform different actions on vertices or edges as they are encountered. These functions give us the freedom to easily customize our response.

5.6.2 Finding Paths

The `parent` array set within `bfs()` is very useful for finding interesting paths through a graph. The vertex that discovered vertex i is defined as `parent[i]`. Every vertex is discovered during the course of traversal, so except for the root every node has a parent. The parent relation defines a tree of discovery with the initial search node as the root of the tree.

Because vertices are discovered in order of increasing distance from the root, this tree has a very important property. The unique tree path from the root to each node $x \in V$ uses the smallest number of edges (or equivalently, intermediate nodes) possible on any root-to- x path in the graph.

We can reconstruct this path by following the chain of ancestors from x to the root. Note that we have to work backward. We cannot find the path from the root to x , since that does not follow the direction of the parent pointers. Instead, we must find the path from x to the root. Since this is the reverse of how we normally want the path, we can either (1) store it and then explicitly reverse it using a stack, or (2) let recursion reverse it for us, as follows:

```
find_path(int start, int end, int parents[])
{
    if ((start == end) || (end == -1))
        printf("\n%d",start);
    else {
        find_path(start,parents[end],parents);
        printf(" %d",end);
    }
}
```

On our breadth-first search graph example (Figure 5.9) our algorithm generated the following parent relation:

vertex	1	2	3	4	5	6
parent	-1	1	2	5	1	1

For the shortest path from 1 to 4, upper-right corner, this parent relation yields the path $\{1, 5, 4\}$.

There are two points to remember when using breadth-first search to find a shortest path from x to y : First, the shortest path tree is only useful if BFS was performed with x as the root of the search. Second, BFS gives the shortest path only if the graph is unweighted. We will present algorithms for finding shortest paths in weighted graphs in Section 6.3.1 (page 206).

5.7 Applications of Breadth-First Search

Most elementary graph algorithms make one or two traversals of the graph while we update our knowledge of the graph. Properly implemented using adjacency lists, any such algorithm is destined to be linear, since BFS runs in $O(n + m)$ time on both directed and undirected graphs. This is optimal, since it is as fast as one can hope to *read* any n -vertex, m -edge graph.

The trick is seeing when traversal approaches are destined to work. We present several examples below.

5.7.1 Connected Components

The “six degrees of separation” theory argues that there is always a short path linking every two people in the world. We say that a graph is *connected* if there is a path between any two vertices. If the theory is true, it means the friendship graph must be connected.

A *connected component* of an undirected graph is a maximal set of vertices such that there is a path between every pair of vertices. The components are separate “pieces” of the graph such that there is no connection between the pieces. If we envision tribes in remote parts of the world that have yet not been encountered, each such tribe would form a separate connected component in the friendship graph. A remote hermit, or extremely unpleasant fellow, would represent a connected component of one vertex.

An amazing number of seemingly complicated problems reduce to finding or counting connected components. For example, testing whether a puzzle such as Rubik’s cube or the 15-puzzle can be solved from any position is really asking whether the graph of legal configurations is connected.

Connected components can be found using breadth-first search, since the vertex order does not matter. We start from the first vertex. Anything we discover during this search must be part of the same connected component. We then repeat the search from any undiscovered vertex (if one exists) to define the next component, and so on until all vertices have been found:

```

connected_components(graph *g)
{
    int c;                /* component number */
    int i;                /* counter */

    initialize_search(g);

    c = 0;
    for (i=1; i<=g->nvertices; i++)
        if (discovered[i] == FALSE) {
            c = c+1;
            printf("Component %d:",c);
            bfs(g,i);
            printf("\n");
        }
}

process_vertex_early(int v)
{
    printf(" %d",v);
}

process_edge(int x, int y)
{
}

```

Observe how we increment a counter c denoting the current component number with each call to `bfs`. We could have explicitly bound each vertex to its component number (instead of printing the vertices in each component) by changing the action of `process_vertex`.

There are two distinct notions of connectivity for directed graphs, leading to algorithms for finding both weakly connected and strongly connected components. Both of these can be found in $O(n + m)$ time, as discussed in Section 15.1 (page 477).

5.7.2 Two-Coloring Graphs

The *vertex-coloring* problem seeks to assign a label (or color) to each vertex of a graph such that no edge links any two vertices of the same color. We can easily avoid all conflicts by assigning each vertex a unique color. However, the goal is to use as few colors as possible. Vertex coloring problems often arise in scheduling applications, such as register allocation in compilers. See Section 16.7 (page 544) for a full treatment of vertex-coloring algorithms and applications.

A graph is *bipartite* if it can be colored without conflicts while using only two colors. Bipartite graphs are important because they arise naturally in many applications. Consider the “had-sex-with” graph in a heterosexual world. Men have sex only with women, and vice versa. Thus, gender defines a legal two-coloring, in this simple model.

But how can we find an appropriate two-coloring of a graph, thus separating the men from the women? Suppose we assume that the starting vertex is male. All vertices adjacent to this man must be female, assuming the graph is indeed bipartite.

We can augment breadth-first search so that whenever we discover a new vertex, we color it the opposite of its parent. We check whether any nondiscovery edge links two vertices of the same color. Such a conflict means that the graph cannot be two-colored. Otherwise, we will have constructed a proper two-coloring whenever we terminate without conflict.

```
twocolor(graph *g)
{
    int i;                                /* counter */

    for (i=1; i<=(g->nvertices); i++)
        color[i] = UNCOLORED;

    bipartite = TRUE;

    initialize_search(&g);

    for (i=1; i<=(g->nvertices); i++)
        if (discovered[i] == FALSE) {
            color[i] = WHITE;
            bfs(g,i);
        }
}

process_edge(int x, int y)
{
    if (color[x] == color[y]) {
        bipartite = FALSE;
        printf("Warning: not bipartite due to (%d,%d)\n",x,y);
    }

    color[y] = complement(color[x]);
}
```



```

complement(int color)
{
    if (color == WHITE) return(BLACK);
    if (color == BLACK) return(WHITE);

    return(UNCOLORED);
}

```

We can assign the first vertex in any connected component to be whatever color/sex we wish. BFS can separate the men from the women, but we can't tell them apart just by using the graph structure.

Take-Home Lesson: Breadth-first and depth-first searches provide mechanisms to visit each edge and vertex of the graph. They prove the basis of most simple, efficient graph algorithms.

5.8 Depth-First Search

There are two primary graph traversal algorithms: *breadth-first search* (BFS) and *depth-first search* (DFS). For certain problems, it makes absolutely no difference which you use, but in others the distinction is crucial.

The difference between BFS and DFS results is in the order in which they explore vertices. This order depends completely upon the container data structure used to store the *discovered* but not *processed* vertices.

- *Queue* – By storing the vertices in a first-in, first-out (FIFO) queue, we explore the oldest unexplored vertices first. Thus our explorations radiate out slowly from the starting vertex, defining a breadth-first search.
- *Stack* – By storing the vertices in a last-in, first-out (LIFO) stack, we explore the vertices by lurching along a path, visiting a new neighbor if one is available, and backing up only when we are surrounded by previously discovered vertices. Thus, our explorations quickly wander away from our starting point, defining a depth-first search.

Our implementation of `dfs` maintains a notion of traversal *time* for each vertex. Our `time` clock ticks each time we enter or exit any vertex. We keep track of the *entry* and *exit* times for each vertex.

Depth-first search has a neat recursive implementation, which eliminates the need to explicitly use a stack:

```

DFS( $G, u$ )
     $state[u]$  = "discovered"
    process vertex  $u$  if desired
     $entry[u]$  =  $time$ 

```

```

time = time + 1
for each v ∈ Adj[u] do
    process edge (u, v) if desired
    if state[v] = “undiscovered” then
        p[v] = u
        DFS(G, v)
state[u] = “processed”
exit[u] = time
time = time + 1

```

The time intervals have interesting and useful properties with respect to depth-first search:

- *Who is an ancestor?* – Suppose that x is an ancestor of y in the DFS tree. This implies that we must enter x before y , since there is no way we can be born before our own father or grandfather! We also must exit y before we exit x , because the mechanics of DFS ensure we cannot exit x until after we have backed up from the search of all its descendants. Thus the time interval of y must be properly nested within ancestor x .
- *How many descendants?* – The difference between the exit and entry times for v tells us how many descendants v has in the DFS tree. The clock gets incremented on each vertex entry and vertex exit, so half the time difference denotes the number of descendants of v .

We will use these entry and exit times in several applications of depth-first search, particularly topological sorting and biconnected/strongly-connected components. We need to be able to take separate actions on each entry and exit, thus motivating distinct `process_vertex_early` and `process_vertex_late` routines called from `dfs`.

The other important property of a depth-first search is that it partitions the edges of an undirected graph into exactly two classes: *tree edges* and *back edges*. The tree edges discover new vertices, and are those encoded in the `parent` relation. Back edges are those whose other endpoint is an ancestor of the vertex being expanded, so they point back into the tree.

An amazing property of depth-first search is that all edges fall into these two classes. Why can't an edge go to a brother or cousin node instead of an ancestor? All nodes reachable from a given vertex v are expanded before we finish with the traversal from v , so such topologies are impossible for undirected graphs. This edge classification proves fundamental to the correctness of DFS-based algorithms.

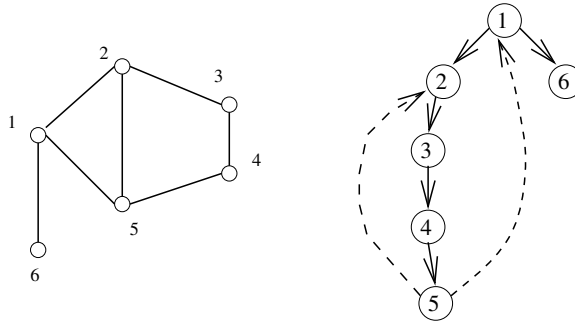

Figure 5.10: An undirected graph and its depth-first search tree

Implementation

A depth-first search can be thought of as a breadth-first search with a stack instead of a queue. The beauty of implementing `dfs` recursively is that recursion eliminates the need to keep an explicit stack:

```
dfs(graph *g, int v)
{
    edgenode *p;           /* temporary pointer */
    int y;                 /* successor vertex */

    if (finished) return; /* allow for search termination */

    discovered[v] = TRUE;
    time = time + 1;
    entry_time[v] = time;

    process_vertex_early(v);

    p = g->edges[v];
    while (p != NULL) {
        y = p->y;
        if (discovered[y] == FALSE) {
            parent[y] = v;
            process_edge(v,y);
            dfs(g,y);
        }
        else if ((!processed[y]) || (g->directed))
            process_edge(v,y);
    }
}
```

```

        if (finished) return;

        p = p->next;
    }

    process_vertex_late(v);

    time = time + 1;
    exit_time[v] = time;

    processed[v] = TRUE;
}

```

Depth-first search use essentially the same idea as backtracking, which we study in Section 7.1 (page 231). Both involve exhaustively searching all possibilities by advancing if it is possible, and backing up as soon as there is no unexplored possibility for further advancement. Both are most easily understood as recursive algorithms.

Take-Home Lesson: DFS organizes vertices by entry/exit times, and edges into tree and back edges. This organization is what gives DFS its real power.

5.9 Applications of Depth-First Search

As algorithm design paradigms go, a depth-first search isn't particularly intimidating. It is surprisingly *subtle*, however meaning that its correctness requires getting details right.

The correctness of a DFS-based algorithm depends upon specifics of exactly *when* we process the edges and vertices. We can process vertex v either before we have traversed any of the outgoing edges from v (`process_vertex_early()`) or after we have finished processing all of them (`process_vertex_late()`). Sometimes we will take special actions at both times, say `process_vertex_early()` to initialize a vertex-specific data structure, which will be modified on edge-processing operations and then analyzed afterwards using `process_vertex_late()`.

In undirected graphs, each edge (x, y) sits in the adjacency lists of vertex x and y . Thus there are two potential times to process each edge (x, y) , namely when exploring x and when exploring y . The labeling of edges as tree edges or back edges occurs during the first time the edge is explored. This first time we see an edge is usually a logical time to do edge-specific processing. Sometimes, we may want to take different action the second time we see an edge.

But when we encounter edge (x, y) from x , how can we tell if we have previously traversed the edge from y ? The issue is easy if vertex y is undiscovered: (x, y)

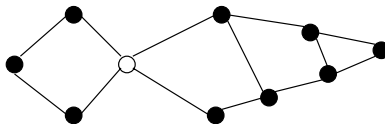

Figure 5.11: An articulation vertex is the weakest point in the graph

becomes a tree edge so this must be the first time. The issue is also easy if y has not been completely processed; since we explored the edge when we explored y this must be the second time. But what if y is an ancestor of x , and thus in a discovered state? Careful reflection will convince you that this must be our first traversal *unless* y is the immediate ancestor of x —i.e., (y, x) is a tree edge. This can be established by testing if `y == parent[x]`.

I find that the subtlety of depth-first search-based algorithms kicks me in the head whenever I try to implement one. I encourage you to analyze these implementations carefully to see where the problematic cases arise and why.

5.9.1 Finding Cycles

Back edges are the key to finding a cycle in an undirected graph. If there is no back edge, all edges are tree edges, and no cycle exists in a tree. But *any* back edge going from x to an ancestor y creates a cycle with the tree path from y to x . Such a cycle is easy to find using `dfs`:

```
process_edge(int x, int y)
{
    if (parent[x] != y) { /* found back edge! */
        printf("Cycle from %d to %d:", y, x);
        find_path(y, x, parent);
        printf("\n\n");
        finished = TRUE;
    }
}
```

The correctness of this cycle detection algorithm depends upon processing each undirected edge exactly once. Otherwise, a spurious two-vertex cycle (x, y, x) could be composed from the two traversals of any single undirected edge. We use the `finished` flag to terminate after finding the first cycle.

5.9.2 Articulation Vertices

Suppose you are a vandal seeking to disrupt the telephone network. Which station in Figure 5.11 should you choose to blow up to cause the maximum amount of

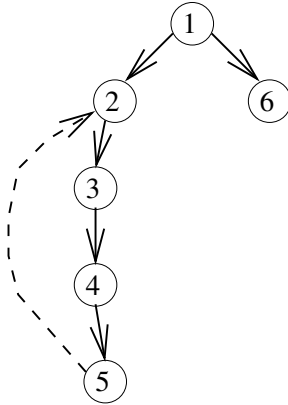

Figure 5.12: DFS tree of a graph containing two articulation vertices (namely 1 and 2). Back edge (5, 2) keeps vertices 3 and 4 from being cut-nodes. Vertices 5 and 6 escape as leaves of the DFS tree

damage? Observe that there is a single point of failure—a single vertex whose deletion disconnects a connected component of the graph. Such a vertex is called an *articulation vertex* or *cut-node*. Any graph that contains an articulation vertex is inherently fragile, because deleting that single vertex causes a loss of connectivity between other nodes.

We presented a breadth-first search-based connected components algorithm in Section 5.7.1 (page 166). In general, the *connectivity* of a graph is the smallest number of vertices whose deletion will disconnect the graph. The connectivity is one if the graph has an articulation vertex. More robust graphs without such a vertex are said to be *biconnected*. Connectivity will be further discussed in the catalog in Section 15.8 (page 505).

Testing for articulation vertices by brute force is easy. Temporarily delete each vertex v , and then do a BFS or DFS traversal of the remaining graph to establish whether it is still connected. The total time for n such traversals is $O(n(m+n))$. There is a clever linear-time algorithm, however, that tests all the vertices of a connected graph using a single depth-first search.

What might the depth-first search tree tell us about articulation vertices? This tree connects all the vertices of the graph. If the DFS tree represented the entirety of the graph, all internal (nonleaf) nodes would be articulation vertices, since deleting any one of them would separate a leaf from the root. Blowing up a leaf (such as vertices 2 and 6 in Figure 5.12) cannot disconnect the tree, since it connects no one but itself to the main trunk.

The root of the search tree is a special case. If it has only one child, it functions as a leaf. But if the root has two or more children, its deletion disconnects them, making the root an articulation vertex.

General graphs are more complex than trees. But a depth-first search of a general graph partitions the edges into tree edges and back edges. Think of these back edges as security cables linking a vertex back to one of its ancestors. The security cable from x back to y ensures that none of the vertices on the tree path between x and y can be articulation vertices. Delete any of these vertices, and the security cable will still hold all of them to the rest of the tree.

Finding articulation vertices requires maintaining the extent to which back edges (i.e., security cables) link chunks of the DFS tree back to ancestor nodes. Let `reachable_ancestor[v]` denote the earliest reachable ancestor of vertex v , meaning the oldest ancestor of v that we can reach by a combination of tree edges and back edges. Initially, `reachable_ancestor[v] = v`:

```
int reachable_ancestor[MAXV+1]; /* earliest reachable ancestor of v */
int tree_out_degree[MAXV+1];   /* DFS tree outdegree of v */

process_vertex_early(int v)
{
    reachable_ancestor[v] = v;
}
```

We update `reachable_ancestor[v]` whenever we encounter a back edge that takes us to an earlier ancestor than we have previously seen. The relative age/rank of our ancestors can be determined from their `entry_time`'s:

```
process_edge(int x, int y)
{
    int class;          /* edge class */

    class = edge_classification(x,y);

    if (class == TREE)
        tree_out_degree[x] = tree_out_degree[x] + 1;

    if ((class == BACK) && (parent[x] != y)) {
        if (entry_time[y] < entry_time[ reachable_ancestor[x] ] )
            reachable_ancestor[x] = y;
    }
}
```

The key issue is determining how the reachability relation impacts whether vertex v is an articulation vertex. There are three cases, as shown in Figure 5.13:

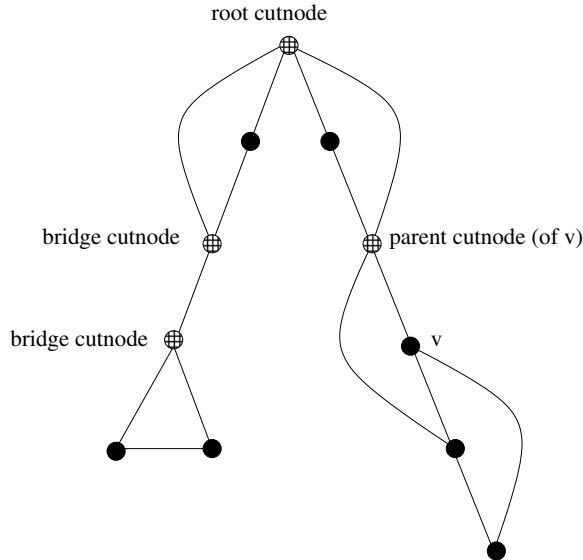

Figure 5.13: The three cases of articulation vertices: root, bridge, and parent cut-nodes

- *Root cut-nodes* – If the root of the DFS tree has two or more children, it must be an articulation vertex. No edges from the subtree of the second child can possibly connect to the subtree of the first child.
- *Bridge cut-nodes* – If the earliest reachable vertex from v is v , then deleting the single edge $(parent[v], v)$ disconnects the graph. Clearly $parent[v]$ must be an articulation vertex, since it cuts v from the graph. Vertex v is also an articulation vertex unless it is a leaf of the DFS tree. For any leaf, nothing falls off when you cut it.
- *Parent cut-nodes* – If the earliest reachable vertex from v is the parent of v , then deleting the parent must sever v from the tree unless the parent is the root.

The routine below systematically evaluates each of the three conditions as we back up from the vertex after traversing all outgoing edges. We use `entry_time[v]` to represent the age of vertex v . The reachability time `time_v` calculated below denotes the oldest vertex that can be reached using back edges. Getting back to an ancestor above v rules out the possibility of v being a cut-node:

```

process_vertex_late(int v)
{
    bool root;          /* is the vertex the root of the DFS tree? */
    int time_v;         /* earliest reachable time for v */
    int time_parent;   /* earliest reachable time for parent[v] */

    if (parent[v] < 1) { /* test if v is the root */
        if (tree_out_degree[v] > 1)
            printf("root articulation vertex: %d \n",v);
        return;
    }

    root = (parent[parent[v]] < 1); /* is parent[v] the root? */
    if ((reachable_ancestor[v] == parent[v]) && (!root))
        printf("parent articulation vertex: %d \n",parent[v]);

    if (reachable_ancestor[v] == v) {
        printf("bridge articulation vertex: %d \n",parent[v]);

        if (tree_out_degree[v] > 0) /* test if v is not a leaf */
            printf("bridge articulation vertex: %d \n",v);
    }

    time_v = entry_time[reachable_ancestor[v]];
    time_parent = entry_time[ reachable_ancestor[parent[v]] ];

    if (time_v < time_parent)
        reachable_ancestor[parent[v]] = reachable_ancestor[v];
}

```

The last lines of this routine govern when we back up a node's highest reachable ancestor to its parent, namely whenever it is higher than the parent's earliest ancestor to date.

We can alternately talk about reliability in terms of edge failures instead of vertex failures. Perhaps our vandal would find it easier to cut a cable instead of blowing up a switching station. A single edge whose deletion disconnects the graph is called a *bridge*; any graph without such an edge is said to be *edge-biconnected*.

Identifying whether a given edge (x, y) is a bridge is easily done in linear time by deleting the edge and testing whether the resulting graph is connected. In fact all bridges can be identified in the same $O(n+m)$ time. Edge (x, y) is a bridge if (1) it is a tree edge, and (2) no back edge connects from y or below to x or above. This can be computed with a minor modification of the `reachable_ancestor` function.

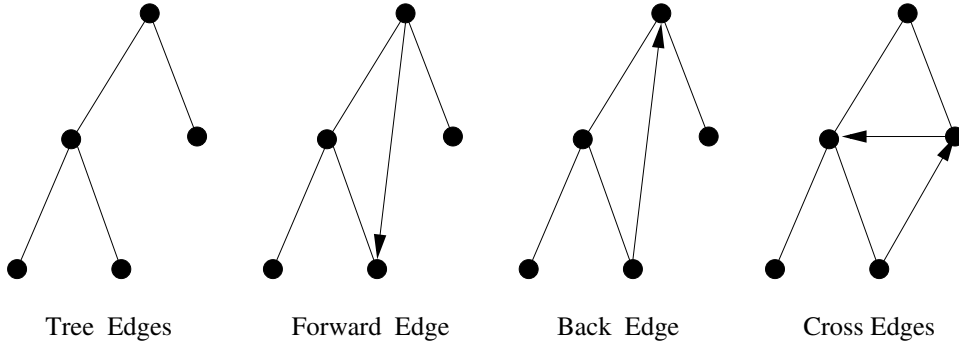

Figure 5.14: Possible edge cases for BFS/DFS traversal

5.10 Depth-First Search on Directed Graphs

Depth-first search on an undirected graph proves useful because it organizes the edges of the graph in a very precise way, as shown in Figure 5.10.

When traversing undirected graphs, every edge is either in the depth-first search tree or a back edge to an ancestor in the tree. Let us review why. Suppose we encountered a “forward edge” (x, y) directed toward a descendant vertex. In this case, we would have discovered (x, y) while exploring y , making it a back edge. Suppose we encounter a “cross edge” (x, y) , linking two unrelated vertices. Again, we would have discovered this edge when we explored y , making it a tree edge.

For directed graphs, depth-first search labelings can take on a wider range of possibilities. Indeed, all four of the edge cases in Figure 5.14 can occur in traversing directed graphs. Still, this classification proves useful in organizing algorithms on directed graphs. We typically take a different action on edges from each different case.

The correct labeling of each edge can be readily determined from the state, discovery time, and parent of each vertex, as encoded in the following function:

```
int edge_classification(int x, int y)
{
    if (parent[y] == x) return(TREE);
    if (discovered[y] && !processed[y]) return(BACK);
    if (processed[y] && (entry_time[y] > entry_time[x])) return(FORWARD);
    if (processed[y] && (entry_time[y] < entry_time[x])) return(CROSS);

    printf("Warning: unclassified edge (%d,%d)\n", x, y);
}
```

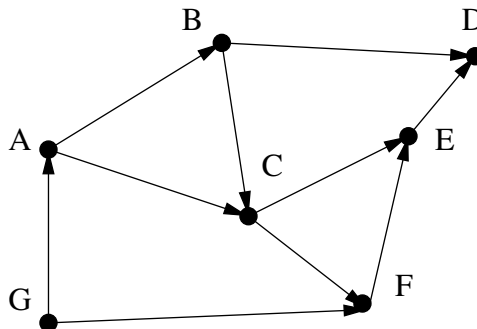

Figure 5.15: A DAG with only one topological sort (G, A, B, C, F, E, D)

As with BFS, this implementation of the depth-first search algorithm includes places to optionally process each vertex and edge—say to copy them, print them, or count them. Both algorithms will traverse all edges in the same connected component as the starting point. Since we need to start with a vertex in each component to traverse a disconnected graph, we must start from any vertex remaining undiscovered after a component search. With the proper initialization, this completes the traversal algorithm:

```

DFS-graph( $G$ )
  for each vertex  $u \in V[G]$  do
     $state[u] = \text{“undiscovered”}$ 
    for each vertex  $u \in V[G]$  do
      if  $state[u] = \text{“undiscovered”}$  then
        initialize new component, if desired
        DFS( $G, u$ )
  
```

I encourage the reader to convince themselves of the correctness of these four conditions. What I said earlier about the subtlety of depth-first search goes double for directed graphs.

5.10.1 Topological Sorting

Topological sorting is the most important operation on directed acyclic graphs (DAGs). It orders the vertices on a line such that all directed edges go from left to right. Such an ordering cannot exist if the graph contains a directed cycle, because there is no way you can keep going right on a line and still return back to where you started from!

Each DAG has at least one topological sort. The importance of topological sorting is that it gives us an ordering to process each vertex before any of its successors. Suppose the edges represented precedence constraints, such that edge

(x, y) means job x must be done before job y . Then, any topological sort defines a legal schedule. Indeed, there can be many such orderings for a given DAG.

But the applications go deeper. Suppose we seek the shortest (or longest) path from x to y in a DAG. No vertex appearing after y in the topological order can contribute to any such path, because there will be no way to get back to y . We can appropriately process all the vertices from left to right in topological order, considering the impact of their outgoing edges, and know that we will have looked at everything we need before we need it. Topological sorting proves very useful in essentially any algorithmic problem on directed graphs, as discussed in the catalog in Section 15.2 (page 481).

Topological sorting can be performed efficiently using depth-first searching. A directed graph is a DAG if and only if no back edges are encountered. Labeling the vertices in the reverse order that they are marked *processed* finds a topological sort of a DAG. Why? Consider what happens to each directed edge $\{x, y\}$ as we encounter it exploring vertex x :

- If y is currently *undiscovered*, then we start a DFS of y before we can continue with x . Thus y is marked *completed* before x is, and x appears before y in the topological order, as it must.
- If y is *discovered* but not *completed*, then $\{x, y\}$ is a back edge, which is forbidden in a DAG.
- If y is *processed*, then it will have been so labeled before x . Therefore, x appears before y in the topological order, as it must.

Study the following implementation:

```
process_vertex_late(int v)
{
    push(&sorted, v);
}

process_edge(int x, int y)
{
    int class;          /* edge class */

    class = edge_classification(x, y);

    if (class == BACK)
        printf("Warning: directed cycle found, not a DAG\n");
}
```

```
topsort(graph *g)
{
    int i;                               /* counter */

    init_stack(&sorted);

    for (i=1; i<=g->nvertices; i++)
        if (discovered[i] == FALSE)
            dfs(g,i);

    print_stack(&sorted);                /* report topological order */
}
```

We push each vertex on a stack as soon as we have evaluated all outgoing edges. The top vertex on the stack always has no incoming edges from any vertex on the stack. Repeatedly popping them off yields a topological ordering.

5.10.2 Strongly Connected Components

We are often concerned with *strongly connected components*—that is, partitioning a graph into chunks such that directed paths exist between all pairs of vertices within a given chunk. A directed graph is *strongly connected* if there is a directed path between any two vertices. Road networks should be strongly connected, or else there will be places you can drive to but not drive home from without violating one-way signs.

It is straightforward to use graph traversal to test whether a graph $G = (V, E)$ is strongly connected in linear time. First, do a traversal from some arbitrary vertex v . Every vertex in the graph had better be reachable from v (and hence discovered on the BFS or DFS starting from v), otherwise G cannot possibly be strongly connected. Now construct a graph $G' = (V, E')$ with the same vertex and edge set as G but with all edges reversed—i.e., directed edge $(x, y) \in E$ iff $(y, x) \in E'$. Thus, any path from v to z in G' corresponds to a path from z to v in G . By doing a DFS from v in G' , we find all vertices with paths *to* v in G . The graph is strongly connected iff all vertices in G can (1) reach v and (2) are reachable from v .

Graphs that are not strongly connected can be partitioned into strongly connected components, as shown in Figure 5.16 (left). The set of such components and the weakly-connecting edges that link them together can be determined using DFS. The algorithm is based on the observation that it is easy to find a directed cycle using a depth-first search, since any back edge plus the down path in the DFS tree gives such a cycle. All vertices in this cycle must be in the same strongly connected component. Thus, we can shrink (contract) the vertices on this cycle down to a single vertex representing the component, and then repeat. This process terminates when no directed cycle remains, and each vertex represents a different strongly connected component.

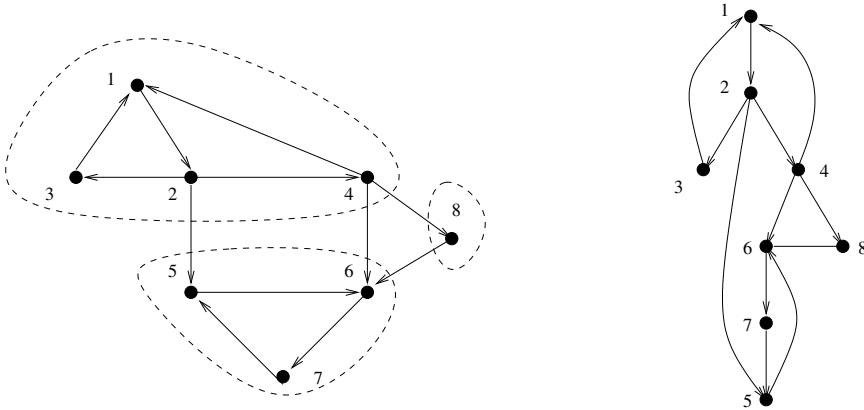

Figure 5.16: The strongly-connected components of a graph, with the associated DFS tree

Our approach to implementing this idea is reminiscent of finding biconnected components in Section 5.9.2 (page 173). We update our notion of the oldest reachable vertex in response to (1) nontree edges and (2) backing up from a vertex. Because we are working on a directed graph, we also must contend with forward edges (from a vertex to a descendant) and cross edges (from a vertex back to a nonancestor but previously discovered vertex). Our algorithm will peel one strong component off the tree at a time, and assign each of its vertices the number of the component it is in:

```

strong_components(graph *g)
{
    int i;                               /* counter */

    for (i=1; i<=(g->nvertices); i++) {
        low[i] = i;
        scc[i] = -1;
    }
    components_found = 0;
    init_stack(&active);
    initialize_search(&g);

    for (i=1; i<=(g->nvertices); i++)
        if (discovered[i] == FALSE) {
            dfs(g,i);
        }
}

```

Define $\text{low}[v]$ to be the oldest vertex known to be in the same strongly connected component as v . This vertex is not necessarily an ancestor, but may also be a distant cousin of v because of cross edges. Cross edges that point vertices from *previous* strongly connected components of the graph cannot help us, because there can be no way back from them to v , but otherwise cross edges are fair game. Forward edges have no impact on reachability over the depth-first tree edges, and hence can be disregarded:

```
int low[MAXV+1];          /* oldest vertex surely in component of v */
int scc[MAXV+1];         /* strong component number for each vertex */

process_edge(int x, int y)
{
    int class;            /* edge class */

    class = edge_classification(x,y);

    if (class == BACK) {
        if (entry_time[y] < entry_time[ low[x] ] )
            low[x] = y;
    }

    if (class == CROSS) {
        if (scc[y] == -1) /* component not yet assigned */
            if (entry_time[y] < entry_time[ low[x] ] )
                low[x] = y;
    }
}
}
```

A new strongly connected component is found whenever the lowest reachable vertex from v is v . If so, we can clear the stack of this component. Otherwise, we give our parent the benefit of the oldest ancestor we can reach and backtrack:

```
process_vertex_early(int v)
{
    push(&active,v);
}
}
```

```
process_vertex_late(int v)
{
    if (low[v] == v) { /* edge (parent[v],v) cuts off scc */
        pop_component(v);
    }

    if (entry_time[low[v]] < entry_time[low[parent[v]]])
        low[parent[v]] = low[v];
}

pop_component(int v)
{
    int t; /* vertex placeholder */

    components_found = components_found + 1;

    scc[ v ] = components_found;
    while ((t = pop(&active)) != v) {
        scc[ t ] = components_found;
    }
}
```

Chapter Notes

Our treatment of graph traversal represents an expanded version of material from Chapter 9 of [SR03]. The *Combinatorica* graph library discussed in the war story is best described in the old [Ski90], and new editions [PS03] of the associated book. Accessible introductions to the science of social networks include Barabasi [Bar03] and Watts [Wat04].

5.11 Exercises

Simulating Graph Algorithms

5-1. [3] For the following graphs G_1 (left) and G_2 (right):

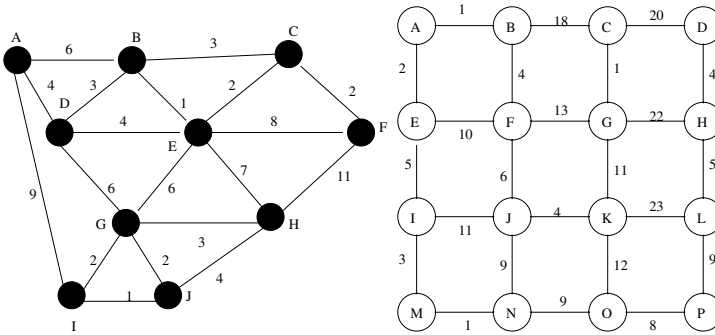

- (a) Report the order of the vertices encountered on a breadth-first search starting from vertex A . Break all ties by picking the vertices in alphabetical order (i.e., A before Z).
- (b) Report the order of the vertices encountered on a depth-first search starting from vertex A . Break all ties by picking the vertices in alphabetical order (i.e., A before Z).

5-2. [3] Do a topological sort of the following graph G :

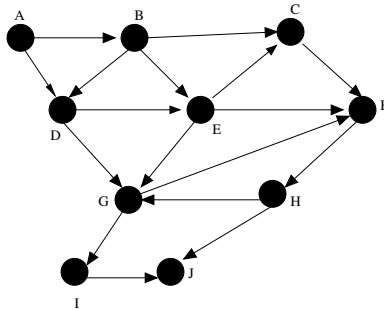

Traversal

- 5-3. [3] Prove by induction that there is a unique path between any pair of vertices in a tree.
- 5-4. [3] Prove that in a breadth-first search on a undirected graph G , every edge is either a tree edge or a cross edge, where x is neither an ancestor nor descendant of y , in cross edge (x, y) .
- 5-5. [3] Give a linear algorithm to compute the chromatic number of graphs where each vertex has degree at most 2. Must such graphs be bipartite?
- 5-6. [5] In breadth-first and depth-first search, an undiscovered node is marked *discovered* when it is first encountered, and marked *processed* when it has been completely

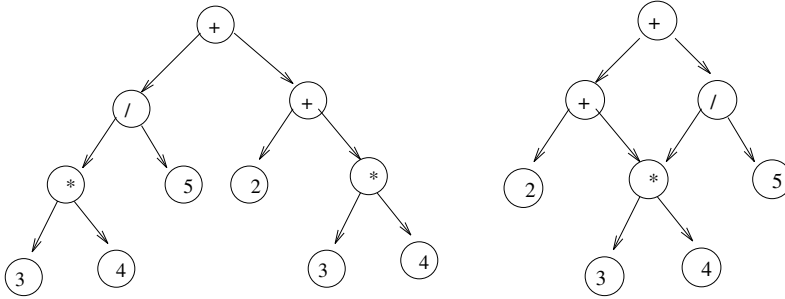

Figure 5.17: Expression $2 + 3 * 4 + (3 * 4)/5$ as a tree and a DAG

searched. At any given moment, several nodes might be simultaneously in the *discovered* state.

- (a) Describe a graph on n vertices and a particular starting vertex v such that $\Theta(n)$ nodes are simultaneously in the *discovered* state during a *breadth-first search* starting from v .
 - (b) Describe a graph on n vertices and a particular starting vertex v such that $\Theta(n)$ nodes are simultaneously in the *discovered* state during a *depth-first search* starting from v .
 - (c) Describe a graph on n vertices and a particular starting vertex v such that at some point $\Theta(n)$ nodes remain *undiscovered*, while $\Theta(n)$ nodes have been *processed* during a *depth-first search* starting from v . (Note, there may also be *discovered* nodes.)
- 5-7. [4] Given pre-order and in-order traversals of a binary tree, is it possible to reconstruct the tree? If so, sketch an algorithm to do it. If not, give a counterexample. Repeat the problem if you are given the pre-order and post-order traversals.
 - 5-8. [3] Present correct and efficient algorithms to convert an undirected graph G between the following graph data structures. You must give the time complexity of each algorithm, assuming n vertices and m edges.
 - (a) Convert from an adjacency matrix to adjacency lists.
 - (b) Convert from an adjacency list to an incidence matrix. An incidence matrix M has a row for each vertex and a column for each edge, such that $M[i, j] = 1$ if vertex i is part of edge j , otherwise $M[i, j] = 0$.
 - (c) Convert from an incidence matrix to adjacency lists.
 - 5-9. [3] Suppose an arithmetic expression is given as a tree. Each leaf is an integer and each internal node is one of the standard arithmetical operations ($+$, $-$, $*$, $/$). For example, the expression $2 + 3 * 4 + (3 * 4)/5$ is represented by the tree in Figure 5.17(a). Give an $O(n)$ algorithm for evaluating such an expression, where there are n nodes in the tree.
 - 5-10. [5] Suppose an arithmetic expression is given as a DAG (directed acyclic graph) with common subexpressions removed. Each leaf is an integer and each internal

node is one of the standard arithmetical operations $(+, -, *, /)$. For example, the expression $2 + 3 * 4 + (3 * 4)/5$ is represented by the DAG in Figure 5.17(b). Give an $O(n + m)$ algorithm for evaluating such a DAG, where there are n nodes and m edges in the DAG. Hint: modify an algorithm for the tree case to achieve the desired efficiency.

- 5-11. [8] The war story of Section 5.4 (page 158) describes an algorithm for constructing the dual graph of the triangulation efficiently, although it does not guarantee linear time. Give a worst-case linear algorithm for the problem.

Algorithm Design

- 5-12. [5] The *square* of a directed graph $G = (V, E)$ is the graph $G^2 = (V, E^2)$ such that $(u, w) \in E^2$ iff there exists $v \in V$ such that $(u, v) \in E$ and $(v, w) \in E$; i.e., there is a path of exactly two edges from u to w .

Give efficient algorithms for both adjacency lists and matrices.

- 5-13. [5] A *vertex cover* of a graph $G = (V, E)$ is a subset of vertices V' such that each edge in E is incident on at least one vertex of V' .

- Give an efficient algorithm to find a minimum-size vertex cover if G is a tree.
- Let $G = (V, E)$ be a tree such that the weight of each vertex is equal to the degree of that vertex. Give an efficient algorithm to find a minimum-weight vertex cover of G .
- Let $G = (V, E)$ be a tree with arbitrary weights associated with the vertices. Give an efficient algorithm to find a minimum-weight vertex cover of G .

- 5-14. [3] A *vertex cover* of a graph $G = (V, E)$ is a subset of vertices $V' \subseteq V$ such that every edge in E contains at least one vertex from V' . Delete all the leaves from any depth-first search tree of G . Must the remaining vertices form a vertex cover of G ? Give a proof or a counterexample.

- 5-15. [5] A *vertex cover* of a graph $G = (V, E)$ is a subset of vertices $V' \subseteq V$ such that every edge in E contains *at least one* vertex from V' . An *independent set* of graph $G = (V, E)$ is a subset of vertices $V' \subseteq V$ such that no edge in E contains both vertices from V' .

An *independent vertex cover* is a subset of vertices that is both an independent set and a vertex cover of G . Give an efficient algorithm for testing whether G contains an independent vertex cover. What classical graph problem does this reduce to?

- 5-16. [5] An *independent set* of an undirected graph $G = (V, E)$ is a set of vertices U such that no edge in E is incident on two vertices of U .

- Give an efficient algorithm to find a maximum-size independent set if G is a tree.
- Let $G = (V, E)$ be a tree with weights associated with the vertices such that the weight of each vertex is equal to the degree of that vertex. Give an efficient algorithm to find a maximum independent set of G .
- Let $G = (V, E)$ be a tree with arbitrary weights associated with the vertices. Give an efficient algorithm to find a maximum independent set of G .

5-17. [5] Consider the problem of determining whether a given undirected graph $G = (V, E)$ contains a *triangle* or cycle of length 3.

(a) Give an $O(|V|^3)$ to find a triangle if one exists.

(b) Improve your algorithm to run in time $O(|V| \cdot |E|)$. You may assume $|V| \leq |E|$.

Observe that these bounds gives you time to convert between the adjacency matrix and adjacency list representations of G .

5-18. [5] Consider a set of movies M_1, M_2, \dots, M_k . There is a set of customers, each one of which indicates the two movies they would like to see this weekend. Movies are shown on Saturday evening and Sunday evening. Multiple movies may be screened at the same time.

You must decide which movies should be televised on Saturday and which on Sunday, so that every customer gets to see the two movies they desire. Is there a schedule where each movie is shown at most once? Design an efficient algorithm to find such a schedule if one exists.

5-19. [5] The *diameter* of a tree $T = (V, E)$ is given by

$$\max_{u, v \in V} \delta(u, v)$$

(where $\delta(u, v)$ is the number of edges on the path from u to v). Describe an efficient algorithm to compute the diameter of a tree, and show the correctness and analyze the running time of your algorithm.

5-20. [5] Given an undirected graph G with n vertices and m edges, and an integer k , give an $O(m + n)$ algorithm that finds the maximum induced subgraph H of G such that each vertex in H has degree $\geq k$, or prove that no such graph exists. An induced subgraph $F = (U, R)$ of a graph $G = (V, E)$ is a subset of U of the vertices V of G , and all edges R of G such that both vertices of each edge are in U .

5-21. [6] Let v and w be two vertices in a directed graph $G = (V, E)$. Design a linear-time algorithm to find the *number* of different shortest paths (not necessarily vertex disjoint) between v and w . Note: the edges in G are unweighted.

5-22. [6] Design a linear-time algorithm to eliminate each vertex v of degree 2 from a graph by replacing edges (u, v) and (v, w) by an edge (u, w) . We also seek to eliminate multiple copies of edges by replacing them with a single edge. Note that removing multiple copies of an edge may create a new vertex of degree 2, which has to be removed, and that removing a vertex of degree 2 may create multiple edges, which also must be removed.

Directed Graphs

5-23. [5] Your job is to arrange n ill-behaved children in a straight line, facing front. You are given a list of m statements of the form “ i hates j ”. If i hates j , then you do not want put i somewhere behind j , because then i is capable of throwing something at j .

(a) Give an algorithm that orders the line, (or says that it is not possible) in $O(m + n)$ time.

- (b) Suppose instead you want to arrange the children in rows such that if i hates j , then i must be in a lower numbered row than j . Give an efficient algorithm to find the minimum number of rows needed, if it is possible.
- 5-24. [3] Adding a single directed edge to a directed graph can reduce the number of weakly connected components, but by at most how many components? What about the number of strongly connected components?
- 5-25. [5] An *arborescence* of a directed graph G is a rooted tree such that there is a directed path from the root to every other vertex in the graph. Give an efficient and correct algorithm to test whether G contains an arborescence, and its time complexity.
- 5-26. [5] A *mother* vertex in a directed graph $G = (V, E)$ is a vertex v such that all other vertices G can be reached by a directed path from v .
- (a) Give an $O(n + m)$ algorithm to test whether a given vertex v is a mother of G , where $n = |V|$ and $m = |E|$.
- (b) Give an $O(n+m)$ algorithm to test whether graph G contains a mother vertex.
- 5-27. [9] A *tournament* is a directed graph formed by taking the complete undirected graph and assigning arbitrary directions on the edges—i.e., a graph $G = (V, E)$ such that for all $u, v \in V$, exactly one of (u, v) or (v, u) is in E . Show that every tournament has a Hamiltonian path—that is, a path that visits every vertex exactly once. Give an algorithm to find this path.

Articulation Vertices

- 5-28. [5] An articulation vertex of a graph G is a vertex whose deletion disconnects G . Let G be a graph with n vertices and m edges. Give a simple $O(n + m)$ algorithm for finding a vertex of G that is *not* an articulation vertex—i.e., whose deletion does not disconnect G .
- 5-29. [5] Following up on the previous problem, give an $O(n + m)$ algorithm that finds a deletion order for the n vertices such that no deletion disconnects the graph. (Hint: think DFS/BFS.)
- 5-30. [3] Suppose G is a connected undirected graph. An edge e whose removal disconnects the graph is called a *bridge*. Must every bridge e be an edge in a depth-first search tree of G ? Give a proof or a counterexample.

Interview Problems

- 5-31. [3] Which data structures are used in depth-first and breath-first search?
- 5-32. [4] Write a function to traverse binary search tree and return the i th node in sorted order.

Programming Challenges

These programming challenge problems with robot judging are available at <http://www.programming-challenges.com> or <http://online-judge.uva.es>.

- 5-1. “Bicoloring” – Programming Challenges 110901, UVA Judge 10004.

- 5-2. “Playing with Wheels” – Programming Challenges 110902, UVA Judge 10067.
- 5-3. “The Tourist Guide” – Programming Challenges 110903, UVA Judge 10099.
- 5-4. “Edit Step Ladders” – Programming Challenges 110905, UVA Judge 10029.
- 5-5. “Tower of Cubes” – Programming Challenges 110906, UVA Judge 10051.